

| CURRENT OWNER            |  | TOPO  | UTILITIES    | STRT / ROAD | LOCATION   | CURRENT ASSESSMENT |       |          |          |
|--------------------------|--|---|--------------|-------------|--|--------------------|-------|----------|----------|
| DERALEAU, GEORGE MICHAEL |  | 1 Level   | 1 All Public | 1 Paved     |  | Description        | Code  | Assessed | Assessed |
| LUGO-DERALEAU, CARMEN    |  |   |              |             | 4  | RESIDENTL          | 1010  | 473,500  | 473,500  |
| 4 SKIPJACK LANE          |  |   |              |             |  | RES LAND           | 1010  | 137,100  | 137,100  |
| <b>SUPPLEMENTAL DATA</b> |  |   |              |             |  |                    |       |          |          |
| HYANNIS MA 02601         |  | Alt Prcl ID<br>Split Zonin<br>BID Parcel<br>ResExpt Q NO APP:<br>#DL 1 LOTS B, C<br>#DL 2 |              |             | Plan Ref. 621/99<br>Land Ct#<br>#SR<br>Life Estate<br>PP STATU |                    | Total |          | 610,600  |
|                          |  | GIS ID F_980119_2706879   |              |             | Assoc Pid#   |                    | Total |          | 610,600  |

801  
 FY2025  
 BARNSTABLE, MA

**VISION**

| RECORD OF OWNERSHIP              |  | BK-VOL/PAGE | SALE DATE  | Q/U | V/I | SALE PRIC | VC | PREVIOUS ASSESSMENTS (HISTORY) |      |          |       |      |          |
|----------------------------------|--|-------------|------------|-----|-----|-----------|----|--------------------------------|------|----------|-------|------|----------|
| DERALEAU, GEORGE MICHAEL         |  | 35514 179   | 11-30-2022 | Q   | I   | 575,000   | 00 | Year                           | Code | Assessed | Year  | Code | Assessed |
| CARANGELO, WILLIAM JR & ROBERT   |  | 35514 175   | 11-30-2022 | U   | I   | 1         | 1F | 2025                           | 1010 | 473,500  | 2024  | 1010 | 448,400  |
| CARANGELO, MARY GLORIA           |  | 35523 238   | 02-20-2022 | U   | I   | 0         | 1F |                                | 1010 | 137,100  |       | 1010 | 137,100  |
| CARANGELO, MARY GLORIA & WILLIAM |  | 30715 0008  | 08-22-2017 | U   | I   | 1         | 1F |                                |      |          |       |      |          |
| CARANGELO, MARY GLORIA           |  | 26939 0009  | 12-12-2012 | U   | I   | 1         | 1T |                                |      |          |       |      |          |
|                                  |  |             |            |     |     |           |    | Total                          |      | 610,600  | Total |      | 585,500  |
|                                  |  |             |            |     |     |           |    | Total                          |      |          | Total |      | 492,000  |

| EXEMPTIONS |      | OTHER ASSESSMENTS        |        |      |             |        |        |          |
|------------|------|--------------------------|--------|------|-------------|--------|--------|----------|
| Year       | Code | Description              | Amount | Code | Description | Number | Amount | Comm Int |
| 2024       | N5C  | NO RESIDENTIAL EXEMPTION |        |      |             |        |        |          |
| Total      |      |                          | 0.00   |      |             |        |        |          |

This signature acknowledges a visit by a Data Collector or Assessor

| ASSESSING NEIGHBORHOOD |           |   |            |
|------------------------|-----------|---|------------|
| Nbhd                   | Nbhd Name | B | Tracing    |
| 0107                   |           |   | Batch HYAN |

| NOTES |  |
|-------|--|
|       |  |

| APPRAISED VALUE SUMMARY       |         |
|-------------------------------|---------|
| Appraised Bldg. Value (Card)  | 419,400 |
| Appraised Xf (B) Value (Bldg) | 50,500  |
| Appraised Ob (B) Value (Bldg) | 3,600   |
| Appraised Land Value (Bldg)   | 137,100 |
| Special Land Value            | 0       |
| Total Appraised Parcel Value  | 610,600 |
| Valuation Method              | C       |
| Total Appraised Parcel Value  | 610,600 |

| BUILDING PERMIT RECORD |            |      |                |        |            |        |            |                                  | VISIT / CHANGE HISTORY |    |      |    |    |                       |
|------------------------|------------|------|----------------|--------|------------|--------|------------|----------------------------------|------------------------|----|------|----|----|-----------------------|
| Permit Id              | Issue Date | Type | Description    | Amount | Insp Date  | % Comp | Date Comp  | Comments                         | Date                   | Id | Type | Is | Cd | Purpost/Result        |
| 20-2237                | 08-18-2020 | 839  | Solar Panel-Re | 8,113  | 09-09-2020 | 100    | 09-09-2020 | Installation of an interconnecte | 06-01-2023             | TR | 02   |    | 20 | Sale Review           |
| 201105468              | 10-03-2011 | IN   | Insulation     | 2,300  | 06-30-2012 | 100    | 06-30-2012 | AIR SEAL-WEATHERSTRIP-I          | 09-09-2020             | TR | 02   |    | 02 | Bldg Permit Completed |
| 50042                  | 11-16-2000 | AD   | Addition       | 6,500  | 02-07-2001 | 100    | 01-01-2001 |                                  | 04-28-2020             | WD |      |    | FR | Field Review          |
| B32882                 | 05-01-1989 | DW   | Dwelling       | 50,000 | 01-15-1995 | 100    | 12-31-1995 | HY 11/2 S                        | 12-06-2017             | KM | 02   |    | 03 | Cycl Insp Comp        |
|                        |            |      |                |        |            |        |            |                                  | 03-31-2014             | JR | 03   |    | 16 | In Office Review      |
|                        |            |      |                |        |            |        |            |                                  | 06-09-2008             | TP | 03   |    | 16 | In Office Review      |

| LAND LINE VALUATION SECTION |          |                |      |    |            |            |                        |         |            |       |       |           |                  |                    |            |            |
|-----------------------------|----------|----------------|------|----|------------|------------|------------------------|---------|------------|-------|-------|-----------|------------------|--------------------|------------|------------|
| B                           | Use Code | Description    | Zone | LA | Land Units | Unit Price | Size Adj               | AC Disc | Site Index | Cond. | Nbhd. | Nbhd. Adj | Notes            | Location Adjustmen | Adj Unit P | Land Value |
| 1                           | 1010     | Single Fam M-0 | RC-  | 4  | 0.150 AC   | 176,344.00 | 5.18399                | 1.0000  | 5          | 1.00  | 0105  | 1.000     |                  | 1.0000             | 914,167.3  | 137,100    |
| Total Card Land Units       |          |                |      |    | 0.15       | AC         | Parcel Total Land Area |         |            |       |       | 0.15      | Total Land Value |                    |            | 137,100    |

| CONSTRUCTION DETAIL |      |                | CONSTRUCTION DETAIL (CONTINUED)      |    |             |
|---------------------|------|----------------|--------------------------------------|----|-------------|
| Element             | Cd   | Description    | Element                              | Cd | Description |
| Style               | 04   | Cape Cod       |                                      |    |             |
| Model               | 01   | Residential    |                                      |    |             |
| Grade:              | C+   | Average Plus   |                                      |    |             |
| Stories             | 1.75 | 1 3/4 Stories  |                                      |    |             |
| Exterior Wall 1     | 14   | Wood Shingle   |                                      |    |             |
| Exterior Wall 2     | 11   | Clapboard      |                                      |    |             |
| Roof Structure      | 03   | Gable/Hip      |                                      |    |             |
| Roof Cover          | 03   | Asph/F Gls/Cmp |                                      |    |             |
| Interior Wall 1     | 05   | Drywall        |                                      |    |             |
| Interior Wall 2     |      |                |                                      |    |             |
| Interior Floor 1    | 14   | Carpet         |                                      |    |             |
| Interior Floor 2    | 12   | Hardwood       |                                      |    |             |
| Heat Fuel           | 03   | Gas            |                                      |    |             |
| Heat Type           | 04   | Hot Air        |                                      |    |             |
| AC Type             | 03   | Central        |                                      |    |             |
| Bedrooms            | 04   | 4 Bedrooms     |                                      |    |             |
| Full Baths          | 2    |                |                                      |    |             |
| Half Baths          | 0    |                |                                      |    |             |
| Extra Fixtures      |      |                |                                      |    |             |
| Total Rooms         | 8    | 8 Rooms        |                                      |    |             |
| Bath Style          |      |                |                                      |    |             |
| Kitchen Style       |      |                |                                      |    |             |
| Occupancy           |      |                |                                      |    |             |
| Sewer Occupan       |      |                |                                      |    |             |
| Accessory Apt       |      |                |                                      |    |             |
| Foundation Alt      | 01   | Poured Conc.   |                                      |    |             |
| Rms Prts            |      |                |                                      |    |             |
| Bath Split          | 20   | 2 Full-0 Half  |                                      |    |             |
|                     |      |                | <b>CONDO DATA</b>                    |    |             |
|                     |      |                | Parcel Id                            | C  | Owne 0.0    |
|                     |      |                | Adjust Type Code Description Factor% |    |             |
|                     |      |                | Condo Flr                            |    |             |
|                     |      |                | Condo Unit                           |    |             |
|                     |      |                | <b>COST / MARKET VALUATION</b>       |    |             |
|                     |      |                | Building Value New                   |    | 493,401     |
|                     |      |                | Year Built                           |    | 1990        |
|                     |      |                | Effective Year Built                 |    | 2005        |
|                     |      |                | Depreciation Code                    |    | A           |
|                     |      |                | Remodel Rating                       |    |             |
|                     |      |                | Year Remodeled                       |    |             |
|                     |      |                | Depreciation %                       |    | 15          |
|                     |      |                | Functional Obsol                     |    | 0           |
|                     |      |                | External Obsol                       |    | 0           |
|                     |      |                | Trend Factor                         |    | 1           |
|                     |      |                | Condition                            |    |             |
|                     |      |                | Condition %                          |    |             |
|                     |      |                | Percent Good                         |    | 85          |
|                     |      |                | RCNLD                                |    | 419,400     |
|                     |      |                | Dep % Ovr                            |    |             |
|                     |      |                | Dep Ovr Comment                      |    |             |
|                     |      |                | Misc Imp Ovr                         |    |             |
|                     |      |                | Misc Imp Ovr Comment                 |    |             |
|                     |      |                | Cost to Cure Ovr                     |    |             |
|                     |      |                | Cost to Cure Ovr Comment             |    |             |

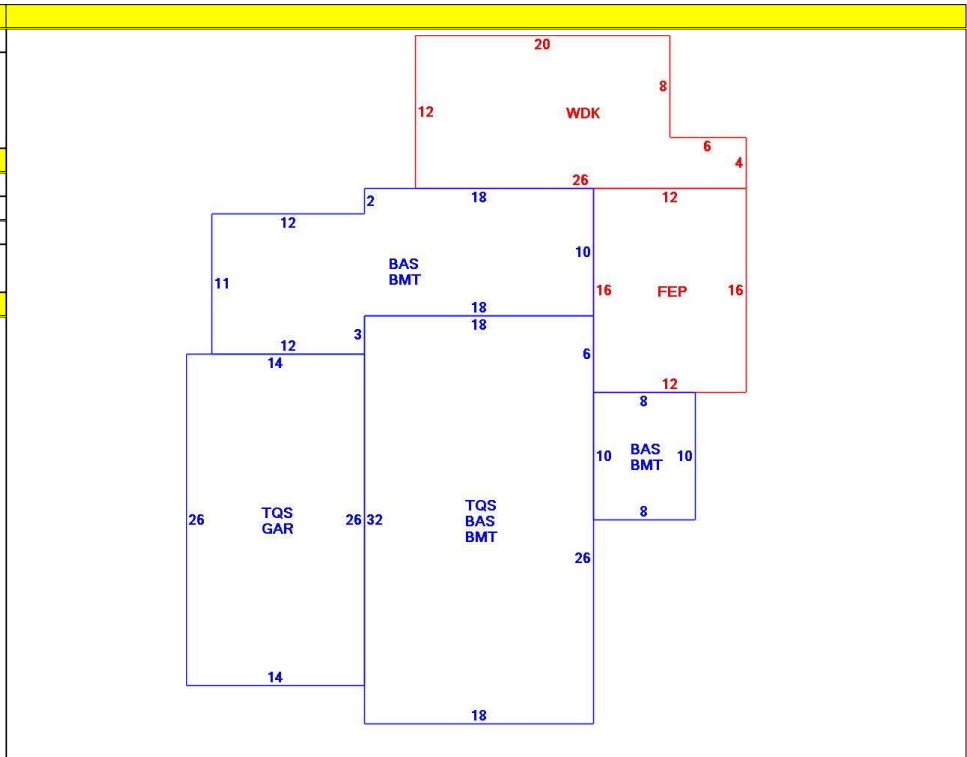

| OB - OUTBUILDING & YARD ITEMS(L) / XF - BUILDING EXTRA FEATURES(B) |                 |     |       |            |        |          |      |       |            |             |
|--|-----------------|-----|-------|------------|--------|----------|------|-------|------------|-------------|
| Code   | Description     | L/B | Units | Unit Price | Yr Blt | Cond. Cd | % Gd | Grade | Grade Adj. | Appr. Value |
| FPL2   | Fireplace 1.5 s | B   | 1     | 6000.00    | 2003   |          | 85   |       | 0.00       | 5,100       |
| WDC  | Wood Decking    | L   | 264   | 20.00      | 2001   |          | 64   |       | 0.00       | 3,600       |
| FEP  | Enclosed porc   | B   | 192   | 70.00      | 2003   |          | 85   |       | 0.00       | 10,400      |
| GAR  | Attached Gara   | B   | 364   | 40.00      | 2003   |          | 85   |       | 0.00       | 12,900      |
| BMT  | Basement-Unfi   | B   | 968   | 26.01      | 2003   |          | 85   |       | 0.00       | 22,100      |
| SOL1   | Solar PV Pane   | B   | 14    | 860.00     | 2003   |          | 0    |       | 0.00       | 0           |

| BUILDING SUB-AREA SUMMARY SECTION |                     |             |            |          |           |                |
|-----------------------------------|---------------------|-------------|------------|----------|-----------|----------------|
| Code                              | Description         | Living Area | Floor Area | Eff Area | Unit Cost | Undeprec Value |
| BAS                               | First Floor         | 968         | 968        | 968      | 312.48    | 302,478        |
| BMT                               | Basement Area       | 0           | 968        | 0        | 0.00      | 0              |
| FEP                               | Enclosed Porch      | 0           | 192        | 0        | 0.00      | 0              |
| GAR                               | Attached Garage     | 0           | 364        | 0        | 0.00      | 0              |
| TQS                               | Three Quarter Story | 611         | 940        | 611      | 203.11    | 190,923        |
| WDK                               | Wood Deck           | 0           | 264        | 0        | 0.00      | 0              |
| Ttl Gross Liv / Lease Area        |                     | 1,579       | 3,696      | 1,579    |           | 493,401        |

