

Key: 10083

Town of Bourne - Fiscal Year 2024

12/18/2023 6:02 pm SEQ #: 10.316

LEGAL

LAND

DETACHED

BUILDING

INDING

CURRENT OWNER				PARCEL ID				LOCATION			
MELVIN JAMES & KRISTINE 479 WINGS NECK RD POCASSET, MA 02559				45.0-24-0				479 WINGS NECK RD			
TRANSFER HISTORY				DOS	T	SALE PRICE	BK-PG (Cert)				
MELVIN JAMES & KRISTINE				05/17/2019	H	1,500,000	32026-139				
MALCOM WILLIAM S ESTATE O				08/29/2014	F		28353-232				
MALCOM WILLIAM S				11/13/1997	O	350,000	11060-261				

CLASS	CLASS%	DESCRIPTION			BN ID	BN	CARD	
1010	100	SINGLE FAMILY				1	1 of 1	
PMT NO	PMT DT	TY	DESC	AMOUNT	INSP	BY	1st	%
B-21-228	06/23/2021	3	ALT/RENO		02/08/2023	TL	100	100
191052	11/12/2019	2	ADDITIONS	250,000	06/05/2023	SL	100	100
19897	09/24/2019	3	ALT/RENO	35,000	04/07/2021		100	100
990229	05/10/1999	3	ALT/RENO	24,000	04/07/2021		100	100
		1	NEW CONSTRUC	130,000	04/23/2003	TL	100	100

CD	T	AC/SF/UN	Nbhd	Infl1	N Index	ADJ BASE	SAF	Topo	Lpi	VC	CREDIT AMT	ADJ VALUE				
100	S	80,000	12	1.00	100	1.00	100	1.00	1,767,750	0.64	A	1.00	WNS	7.50		2,093,700
300	A	0.063	12	1.00	100	1.00	100	1.00	122,250	1.00	A	1.00	WNS	7.50		7,700

TOTAL	1.900 Acres		ZONING	2	FRNT	0	ASSESSED	CURRENT	PREVIOUS
Nbhd	WINGS NCK		NOTE	LAND			2,101,400	1,859,800	
Infl1	AVG			BUILDING			878,000	622,800	
N_Index	AVG			DETACHED			1,500	1,000	
				OTHER			0	0	
				TOTAL			2,980,900	2,483,600	

TY	QUAL	COND	DIM/NOTE	YB	UNITS	ADJ PRICE	RCNLD	
SHF	A	1.00	50 0.50	12 X 16		192	15.95	1,500



BUILDING	CD	ADJ	DESC	MEASURE	2/8/2023	TL
MODEL	1		RESIDENTIAL	LIST	6/5/2023	TL
STYLE	5	1.00	COLONIAL [100%]	REVIEW	7/6/2023	RP
QUALITY	+	1.05	AVERAGE + [100%]			
FRAME	1	1.00	WOOD FRAME [100%]			

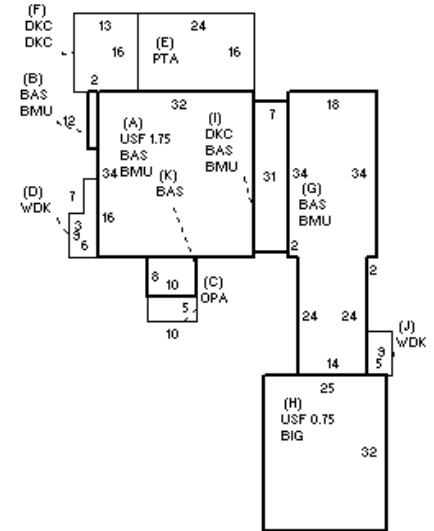

YEAR BLT	1999	SIZE ADJ	0.980	ELEMENT	CD	DESCRIPTION	ADJ	S	BAT	T	DESCRIPTION	UNITS	YB	ADJ PRICE	RCN	TOTAL RCN	944,101
NET AREA	4,861	DETAIL ADJ	1.000	FOUNDATION	4	FLR/WALL(FULL)	1.00	+	BMU	N	BSMT UNFINISHED	2,277		32.23	73,385	CONDITION ELEM	CD
\$NLA(RCN)	\$194	OVERALL	1.090	EXT COVER	1	WOOD SHINGLE	1.02	A	USF	L	UPPER STORY FIN	1,904	1999	97.18	185,024	EXTERIOR	A
				ROOF SHAPE	2	HIP	1.02	C	OPA	N	OPEN PORCH	50		91.39	4,569	INTERIOR	A
				ROOF COVER	1	ASPH/COMP SHIN	1.00	+	WDK	N	WOOD DECK	120		44.32	5,319	KITCHEN	G
				FLOOR COVER	2	SOFTWOOD	1.02	E	PTA	N	PATIO	384		15.25	5,856	BATHS	G
				INT. FINISH	5	OTHER	1.00	+	DKC	N	DECK-COMPOSITE	633		69.59	44,052	HEAT	A
				HEATING/COOLING	9	WARM-COOL AIR	1.03	+	BAS	L	BASE AREA	1,165	2021	192.76	224,570	ELECT	A
				FUEL SOURCE	2	GAS	1.00	H	BIG	N	BUILT-IN GARAGE	800		82.72	66,174		
				USE	0		1.00	H	USF	L	UPPER STORY FIN	600	2021	97.18	58,306		
								+	BAS	L	BASE AREA	1,192	1999	192.76	229,775		
									F31	O	FPL 3S 1OP	1		11,241.90	11,242		
									FIX	O	XTRA FIXTURES	15		2,388.58	35,829		

EFF.YR/AGE	2012 / 10	
COND	7	7 %
FUNC	0	
ECON	0	
DEPR	7	% GD 93
RCNLD	\$878,000	