

Key: 10085

Town of Bourne - Fiscal Year 2024

12/18/2023 6:02 pm SEQ #: 10.318

LEGAL

Table with columns: CURRENT OWNER, PARCEL ID, LOCATION, TRANSFER HISTORY, DOS, T, SALE PRICE, BK-PG (Cert). Includes owner BASS MICHAEL A TRS and parcel 45.0-26-0.

Table with columns: CLASS, CLASS%, DESCRIPTION, BN ID, BN, CARD. Includes entry for NEW CONSTRUCT on 04/23/2001.

LAND

Table with columns: CD, T, AC/SF/UN, Nbhd, Infl1, N Index, ADJ BASE, SAF, Topo, Lpi, VC, CREDIT AMT, ADJ VALUE.

Table with columns: TOTAL, 4.388 Acres, ZONING, 2, FRNT, 0, ASSESSED, CURRENT, PREVIOUS. Includes sub-table for WINGS NCK zoning.

DETACHED

Table with columns: TY, QUAL, COND, DIM/NOTE, YB, UNITS, ADJ PRICE, RCNLD. Includes a photo of the property dated 05/13/2021.

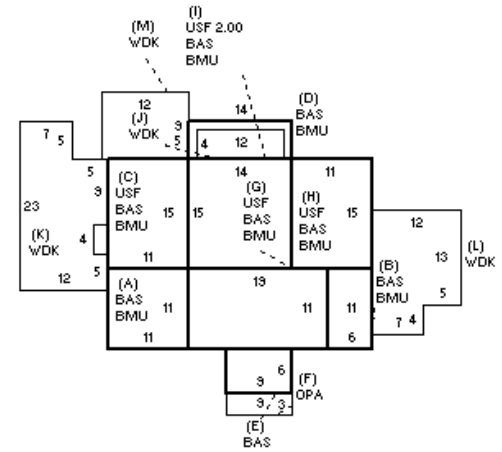

Table with columns: BLDG COMMENTS.

BUILDING

Table with columns: BUILDING, CD, ADJ, DESC, MEASURE, 5/9/2018, TL. Includes details for RESIDENTIAL building.

Table with columns: YEAR BLT, 2001, SIZE ADJ, 1.005, NET AREA, 2,019, DETAIL ADJ, 1.000, \$NLA(RCN), \$438, OVERALL, 1.160. Includes capacity and unit details.

Table with columns: ELEMENT, CD, DESCRIPTION, ADJ. Lists building elements like FOUNDATION, ROOF SHAPE, FLOOR COVER, etc.

Table with columns: S, BAT, T, DESCRIPTION, UNITS, YB, ADJ PRICE, RCN. Lists building systems like BMU, USF, OPA, WDK, F21, FIX.

Table with columns: TOTAL RCN, 885.180, CONDITION ELEM, CD. Includes summary of exterior, interior, kitchen, baths, heat, and elect.