

Key: 10322

Town of Bourne - Fiscal Year 2024

12/18/2023 6:02 pm SEQ #: 10.559

LEGAL

Table with columns: CURRENT OWNER, PARCEL ID, LOCATION, TRANSFER HISTORY, DOS, T, SALE PRICE, BK-PG (Cert). Includes owner name: PREVETT ANTHONY J, MARY M PREVETT, PO BOX 775, CATAUMET, MA 02534-0775.

Table with columns: CLASS, CLASS%, DESCRIPTION, BN ID, BN, CARD. Includes description: SINGLE FAMILY, DETACH.STRUC, and values for BN ID, BN, 1st, %.

LAND

Table with columns: CD, T, AC/SF/UN, Nbhd, Infl1, N Index, ADJ BASE, SAF, Topo, Lpi, VC, CREDIT AMT, ADJ VALUE. Includes values for land area and adjusted value.

Table with columns: TOTAL, 25,003 SF, ZONING, 1, FRNT, 0, ASSESSED, CURRENT, PREVIOUS. Includes assessed values for LAND, BUILDING, DETACHED, OTHER, and TOTAL.

Table with columns: TY, QUAL, COND, DIM/NOTE, YB, UNITS, ADJ PRICE, RCNLD. Includes property details like FLD, PPD, dimensions, and unit counts.

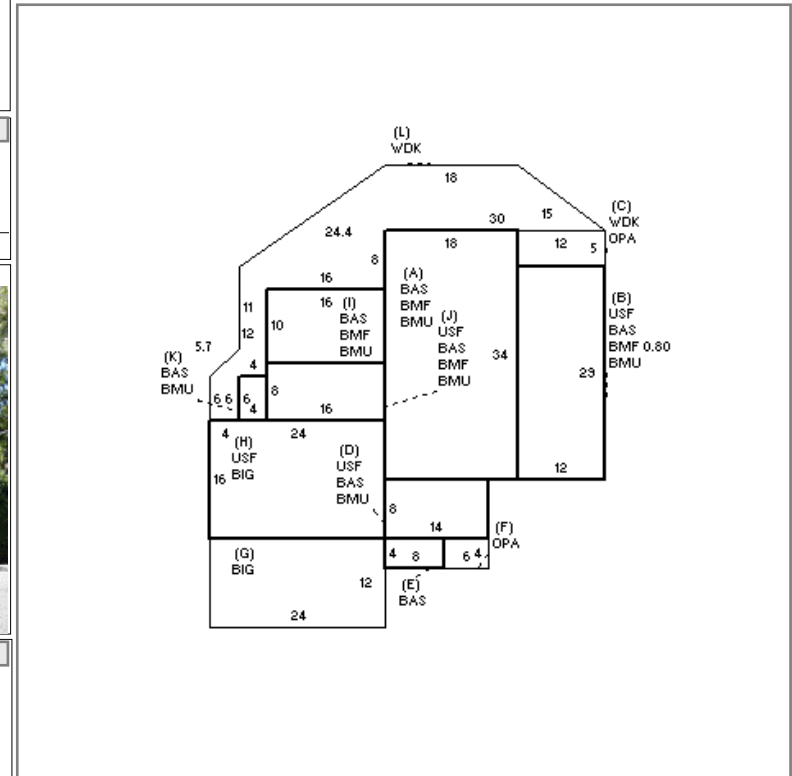

DETACHED

Table with columns: BUILDING, CD, ADJ, DESC, MEASURE, 2/24/2012, DB. Includes building details like MODEL, STYLE, QUALITY, FRAME.

BUILDING

Large table with columns: YEAR BLT, SIZE ADJ, UNITS, ADJ, ELEMENT, CD, DESCRIPTION, ADJ, S, BAT, T, DESCRIPTION, UNITS, YB, ADJ PRICE, RCN, TOTAL RCN, CONDITION ELEM, CD. Includes detailed building specifications and a summary of RCN values.