

Key: 10389

Town of Bourne - Fiscal Year 2024

12/18/2023 6:02 pm SEQ #: 10.621

LEGAL LAND

Table with columns: CURRENT OWNER, PARCEL ID, LOCATION, TRANSFER HISTORY, DOS, T, SALE PRICE, BK-PG (Cert)

Table with columns: CLASS, CLASS%, DESCRIPTION, BN ID, BN, CARD, PMT NO, PMT DT, TY, DESC, AMOUNT, INSP, BY, 1st, %

Table with columns: CD, T, AC/SF/UN, Nbhd, Infl1, N Index, ADJ BASE, SAF, Topo, Lpi, VC, CREDIT AMT, ADJ VALUE

Table with columns: TOTAL, 11,021 SF, ZONING, FRNT, 0, ASSESSED, CURRENT, PREVIOUS

Table with columns: TY, QUAL, COND, DIM/NOTE, YB, UNITS, ADJ PRICE, RCNLD

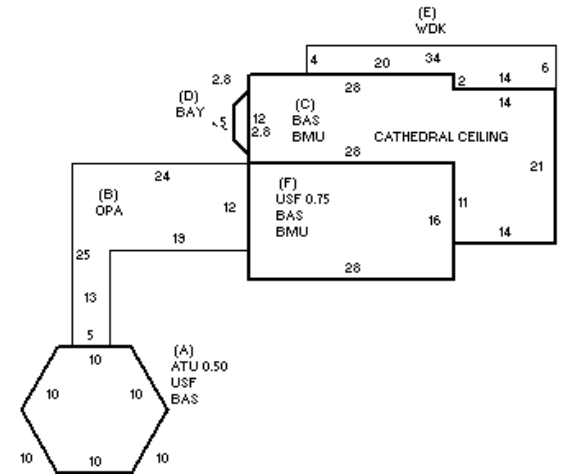

BLDG COMMENTS table with columns for building details and dates.

DETACHED

BUILDING

Table with columns: BUILDING, CD, ADJ, DESC, MEASURE, 4/20/2018, BC

Table with columns: YEAR BLT, 1800, SIZE ADJ, 1.010, NET AREA, 1,948, DETAIL ADJ, 1.000, \$NLA(RCN), \$264, OVERALL, 1.110

Table with columns: ELEMENT, CD, DESCRIPTION, ADJ

Table with columns: S, BAT, T, DESCRIPTION, UNITS, YB, ADJ PRICE, RCN

Table with columns: TOTAL RCN, 513.997, CONDITION ELEM, CD, EFF. YR/AGE, 1997 / 25, COND, 22 22 %, FUNC, 0, ECON, 0, DEPR, 22 % GD, 78, RCNLD, \$400,900