

Key: 1049

Town of Bourne - Fiscal Year 2024

12/18/2023 6:02 pm SEQ #: 1.057

LEGALS

CURRENT OWNER				PARCEL ID				LOCATION				
DOUGENIK MATTHEW A & MICHELLE DOUGENIK 40 FIELDWOOD DR SAGAMORE BEACH, MA 02562				6.0-129-0				40 FIELDWOOD DR				
				TRANSFER HISTORY				DOS	T	SALE PRICE	BK-PG (Cert)	
				DOUGENIK MATTHEW A & DEMBOWSKI STEFAN ETUX ADAMS DAVID T ETUX				07/02/2020	QS	565,000	(222944)	
						08/20/2015	QS	475,000	(207169)			
						12/23/2013	F	1	(202355)			

CLASS	CLASS%	DESCRIPTION			BN ID	BN	CARD	
1010	100	SINGLE FAMILY				1	1 of 1	
PMT NO	PMT DT	TY	DESC	AMOUNT	INSP	BY	1st	%
EXB-21-542	08/04/2021	15	INSULATE/WEA	3,091				
		3	ALT/RENO		07/08/2020	RP	100	100
15761	08/31/2015	14	SOLAR	24,000	04/08/2016		100	100
		12	CYCLICAL		10/16/2014	TL	100	100
02092	02/27/2002	8	POOL	19,000	03/12/2003	TL	100	100

LAND

CD	T	AC/SF/UN	Nbhd	Infl1	N Index	ADJ BASE	SAF	Topo	Lpi	VC	CREDIT AMT	ADJ VALUE					
100	S	26,266	1	1.00	100	1.00	100	1.00	259,270	1.37	A	1.00	R04	1.10			214,320

DETAILED

TOTAL	26,267 SF	ZONING	1	FRNT	178	ASSESSED	CURRENT	PREVIOUS
Nbhd	N SAG	NOTE	LAND	214,300	189,700			
Infl1	AVG		BUILDING	494,000	437,100			
N_Index	AVG		DETACHED	45,700	43,400			
			OTHER	0	0			
			TOTAL	754,000	670,200			

TY	QUAL	COND	DIM/NOTE	YB	UNITS	ADJ PRICE	RCNLD	
IPG	S	3.00	10 0.90	18 X 36	2002	648	78.29	45,700

PHOTO 11/06/2014

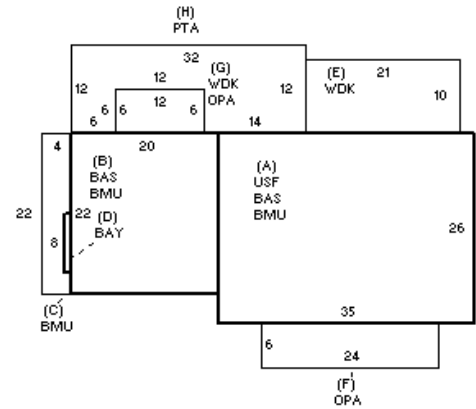

BUILDING

BUILDING	CD	ADJ	DESC	MEASURE	7/14/2021	NMP
MODEL	1		RESIDENTIAL	LIST	5/17/2021	EST
STYLE	5	1.00	COLONIAL [100%]	REVIEW	5/17/2021	RP
QUALITY	G	1.10	GOOD [100%]			
FRAME	1	1.00	WOOD FRAME [100%]			

BLDG COMMENTS		

G

YEAR BLT	1998	SIZE ADJ	1.005	ELEMENT	CD	DESCRIPTION	ADJ	S	BAT	T	DESCRIPTION	UNITS	YB	ADJ PRICE	RCN	TOTAL RCN	574,389
NET AREA	2,268	DETAIL ADJ	1.000	FOUNDATION	4	FLR/WALL(FULL)	1.00	+	BMU	N	BSMT UNFINISHED	1,438		38.14	54,848		
\$NLA(RCN)	\$253	OVERALL	1.080	EXT COVER	1	WOOD SHINGLE	1.02	+	BAS	L	BASE AREA	1,350	1998	224.44	302,992		
				ROOF SHAPE	2	HIP	1.02	A	USF	L	UPPER STORY FIN	910	1998	128.53	116,961		
				ROOF COVER	1	ASPH/COMP SHIN	1.00	D	BAY	L	BAYWINDOW	8	1998	216.25	1,730		
				FLOOR COVER	1	HARDWOOD	1.02	+	WDK	N	WOOD DECK	282		30.92	8,721		
				INT. FINISH	2	DRYWALL	1.00	+	OPA	N	OPEN PORCH	216		70.27	15,177		
				HEATING/COOLING	2	HOT WATER	1.02	H	PTA	N	PATIO	312		16.23	5,065		
				FUEL SOURCE	2	GAS	1.00		BMF	N	BSMT FINISH	700		52.31	36,618		
				USE	0		1.00		BMG	O	BSMT GARAGE	2		8,510.40	17,021		
									FIX	O	XTRA FIXTURES	6		2,542.70	15,256		

CONDITION ELEM	CD
EXTERIOR	A
INTERIOR	A
KITCHEN	G
BATHS	G
HEAT	A
ELECT	A

EFF.YR/AGE	2005 / 17
COND	14 14 %
FUNC	0
ECON	0
DEPR	14 % GD 86
RCNLD	\$494,000