

Key: 10556

Town of Bourne - Fiscal Year 2024

12/18/2023 6:02 pm SEQ #: 10.801

LEGAL

LAND

DETACHED

BUILDING

CURRENT OWNER		PARCEL ID	LOCATION		
CARCHIDI SAM F & THERESA C CARCHIDI CO-TRS PO BOX 324 CATAUMET, MA 02534		50.0-16-0	457 SCRAGGY NECK RD		
TRANSFER HISTORY		DOS	T	SALE PRICE	BK-PG (Cert)
CARCHIDI SAM F &		05/13/1997	XX		10746-288

CLASS	CLASS%	DESCRIPTION		BN ID	BN	CARD	
1010	100	SINGLE FAMILY			1	1 of 1	
PMT NO	PMT DT	TY	DESC	AMOUNT	INSP	BY	1st %
11403	07/18/2011	3	ALT/RENO		05/18/2021	TL	100 100
03189	04/08/2003	4	DETACH.STRUC	2,975	02/03/2015	TL	100 100
		3	ALT/RENO	6,000	06/22/2004	TL	100 100

CD	T	AC/SF/UN	Nbhd	Infl1	N Index	ADJ BASE	SAF	Topo	Lpi	VC	CREDIT AMT	ADJ VALUE				
100	S	40,000	15	1.00	100	1.00	100	1.00	942,800	1.00	A	1.00	BAV	4.00		865,580
300	A	0.142	15	1.00	100	1.00	100	1.00	65,200	1.00	A	1.00	BAV	4.00		9,260

TOTAL	1.060 Acres	ZONING	1	FRNT	0	ASSESSED	CURRENT	PREVIOUS
Nbhd	SCRAG NCK	NOTE	LAND	874,800	774,200			
Infl1	AVG		BUILDING	319,900	283,100			
N_Index	AVG		DETACHED	0	0			
			OTHER	0	0			
		TOTAL	1,194,700	1,057,300				

TY	QUAL	COND	DIM/NOTE	YB	UNITS	ADJ PRICE	RCNLD
SHF	A	1.00	10 0.90 8X12	2011		0.00	

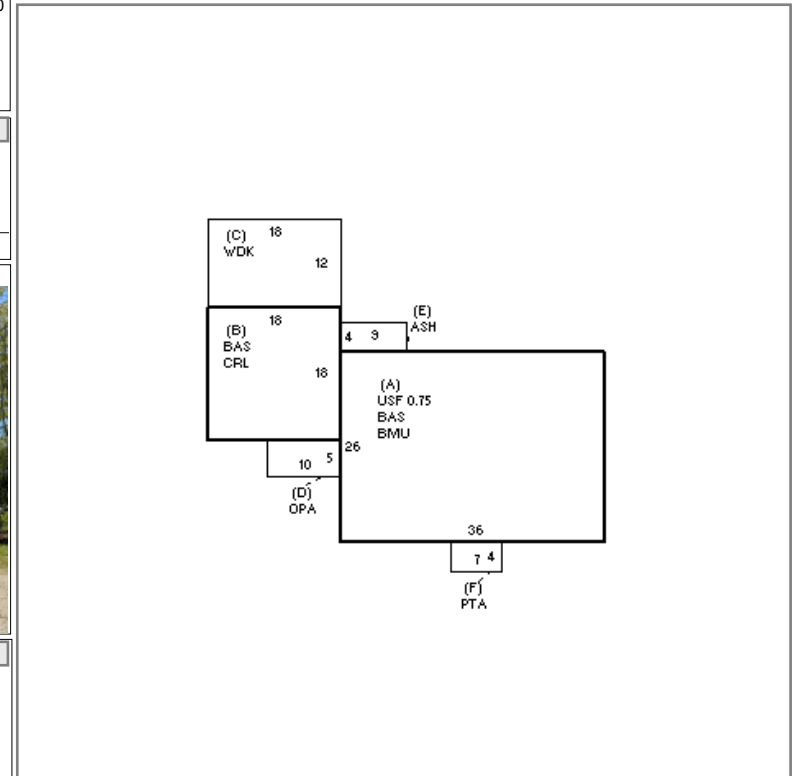

BUILDING	CD	ADJ	DESC	MEASURE	5/18/2021	TL
MODEL	1		RESIDENTIAL	LIST	5/18/2021	EST
STYLE	4	1.05	CAPE [100%]	REVIEW	5/18/2021	TL
QUALITY	A	1.00	AVERAGE [100%]			
FRAME	1	1.00	WOOD FRAME [100%]			

BLDG COMMENTS

YEAR BLT	1967	SIZE ADJ	1.010	ELEMENT	CD	DESCRIPTION	ADJ	S	BAT	T	DESCRIPTION	UNITS	YB	ADJ PRICE	RCN	TOTAL RCN	410,137
NET AREA	1,962	DETAIL ADJ	1.000	FOUNDATION	4	FLR/WALL(FULL)	1.00	A	BMU	N	BSMT UNFINISHED	936		38.67	36,196	CONDITION ELEM	CD
\$NLA(RCN)	\$209	OVERALL	1.050	EXT COVER	1	WOOD SHINGLE	1.02	+	BAS	L	BASE AREA	1,260	1967	199.35	251,187	EXTERIOR	G
				ROOF SHAPE	1	GABLE	1.00	A	USF	L	UPPER STORY FIN	702	1967	115.31	80,949	INTERIOR	A
				ROOF COVER	1	ASPH/COMP SHIN	1.00	B	CRL	N	BSMT CRAWL	324		36.33	11,772	KITCHEN	A
				FLOOR COVER	3	W/W CARPET	1.00	C	WDK	N	WOOD DECK	216		27.46	5,932	BATHS	A
				INT. FINISH	1	PLASTER	1.00	D	OPA	N	OPEN PORCH	50		86.41	4,321	HEAT	A
				HEATING/COOLING	5	ELECTRIC BB	0.98	E	ASH	N	ATT SHED	36		26.36	949	ELECT	A
				FUEL SOURCE	3	ELECTRIC	1.00	F	PTA	N	PATIO	28		16.29	456		
				USE	0		1.00	F21	O	FPL 2S 1OP	1		9,341.90	9,342			
								FIX	O	XTRA FIXTURES	4		2,258.33	9,033			
																EFF.YR/AGE	1997 / 25
																COND	22 22 %
																FUNC	0
																ECON	0
																DEPR	22 % GD 78
																RCNLD	\$319,900