

Key: 10683

Town of Bourne - Fiscal Year 2024

12/18/2023 6:02 pm SEQ #: 10.949

LEGAL

CURRENT OWNER				PARCEL ID				LOCATION			
ROSS ANTONIA L - TR 386 NEW MEADOW RD BARRINGTON, RI 02806				50.0-142-0				424 SCRAGGY NECK RD			
TRANSFER HISTORY				DOS	T	SALE PRICE	BK-PG (Cert)				
ROSS ANTONIA L - TR				04/06/2017	F		1 30401-264				
ROSS ANTONIA L				04/23/2008	F		1 22853-185				
LABATE RUTH R					XX		02945-0177				

CLASS	CLASS%	DESCRIPTION			BN ID	BN	CARD	
1010	100	SINGLE FAMILY				1	1 of 1	
PMT NO	PMT DT	TY	DESC	AMOUNT	INSP	BY	1st	%
04456	06/18/2004	3	ALT/RENO		05/18/2021	TL	100	100
		3	ALT/RENO	5,000	03/25/2005	TL	100	100

LAND

CD	T	AC/SF/UN	Nbhd	Infl1	N Index	ADJ BASE	SAF	Topo	Lpi	VC	CREDIT AMT	ADJ VALUE				
100	S	40,000	15	1.00	100	1.00	100	1.00	3,181,950	1.00	A	1.00	BSP	13.50		2,921,320
325	A	1,232	15	1.00	100	1.00	100	1.00	76,950	1.00	A	1.00	BSP	13.50		94,800

TOTAL	2.150 Acres	ZONING	1	FRNT	0	ASSESSED	CURRENT	PREVIOUS
Nbhd	SCRAG NCK	NOTE	LAND	3,016,100	2,669,100			
Infl1	AVG		BUILDING	763,300	675,500			
N_Index	AVG		DETACHED	1,500	1,400			
			OTHER	0	0			
			TOTAL	3,780,900	3,346,000			

DETACHED

TY	QUAL	COND	DIM/NOTE	YB	UNITS	ADJ PRICE	RCNLD
SHF	A	1.00	A 0.75		120	16.42	1,500

PHOTO 05/18/2021

BLDG COMMENTS

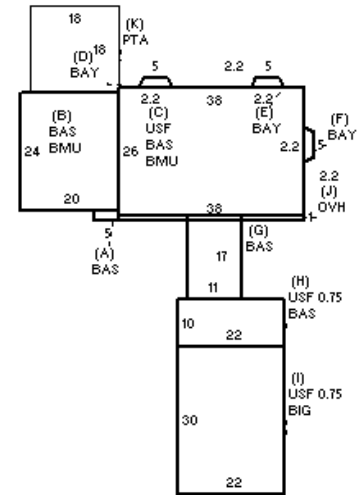

BUILDING

BUILDING	CD	ADJ	DESC	MEASURE	5/18/2021	TL
MODEL	1		RESIDENTIAL	LIST	5/18/2021	EST
STYLE	5	1.00	COLONIAL [100%]	REVIEW		
QUALITY	V	1.35	VERY GOOD [100%]			
FRAME	1	1.00	WOOD FRAME [100%]			

G

YEAR BLT	1948	SIZE ADJ	0.990	ELEMENT	CD	DESCRIPTION	ADJ	S	BAT	T	DESCRIPTION	UNITS	YB	ADJ PRICE	RCN	TOTAL RCN	954,159	
NET AREA	3,607	DETAIL ADJ	1.000	FOUNDATION	3	FOUN. WALL	1.00	+	BAS	L	BASE AREA	1,885	1948	258.02	486,367	CONDITION ELEM	CD	
\$NLA(RCN)	\$265	OVERALL	1.090	EXT COVER	1	WOOD SHINGLE	1.02	+	BMU	N	BSMT UNFINISHED	1,468		46.54	68,319	EXTERIOR	A	
				ROOF SHAPE	1	GABLE	1.00	+	USF	L	UPPER STORY FIN	1,648	1948	151.46	249,604	INTERIOR	A	
				ROOF COVER	2	WOOD SHINGLES	1.02	+	BAY	L	BAYWINDOW	36	1948	263.84	9,498	KITCHEN	G	
				FLOOR COVER	1	HARDWOOD	1.02	I	BIG	N	BUILT-IN GARAGE	660		107.44	70,908	BATHS	G	
				INT. FINISH	2	DRYWALL	1.00	J	OVH	L	OVERHANG	38	1948	263.83	10,026	HEAT	A	
				HEATING/COOLING	9	WARM-COOL AIR	1.03	K	PTA	N	PATIO	324		19.81	6,419	ELECT	A	
				FUEL SOURCE	1	OIL	1.00	F12	O	FPL 1S 2OP	1		12,266.10	12,266				
				USE	0		1.00	F21	O	FPL 2S 1OP	1		12,832.80	12,833				
								FIX	O	XTRA FIXTURES	9		3,102.30	27,921				
																	EFF.YR/AGE	1999 / 23
																	COND	20 20 %
																	FUNC	0
																	ECON	0
																	DEPR	20 % GD 80
																	RCNLD	\$763,300