

Key: 10688

Town of Bourne - Fiscal Year 2024

12/18/2023 6:02 pm SEQ #: 10.954

LEGAL

LAND

DETACHED

BUILDING

CURRENT OWNER				PARCEL ID				LOCATION			
TEPLOW THEODORE H & CHARLOTTE TRS OF TEPLOW CATAUMET RLTY TR 989 MEMORIAL DR #391 CAMBRIDGE, MA 02138-5734				50.0-147-0				400 SCRAGGY NECK RD			
TRANSFER HISTORY				DOS	T	SALE PRICE	BK-PG (Cert)				
TEPLOW THEODORE H & CHARL				01/04/1995	XX		9508-197				

CLASS	CLASS%	DESCRIPTION		BN ID	BN	CARD	
1010	100	SINGLE FAMILY			1	1 of 1	
PMT NO	PMT DT	TY	DESC	AMOUNT	INSP	BY	1st %
940575	11/22/1994	3	ALT/RENO		05/18/2021	TL	100 100
		12	CYCLICAL		04/18/2018	DB	100 100
		2	ADDITIONS	97,000	05/28/1996	JC	100 100

CD	T	AC/SF/UN	Nbhd	Infl1	N Index	ADJ BASE	SAF	Topo	Lpi	VC	CREDIT AMT	ADJ VALUE		
100	S	40,000	15	1.00	DCK 1.00	100	1.00	3,181,950	1.00	A	1.00	BSP 13.50	2,921,320	
325	A	0.412	15	1.00	100	1.00	100	1.00	76,950	1.00	A	1.00	BSP 13.50	31,700

TOTAL	1.330 Acres	ZONING	1	FRNT	0	ASSESSED	CURRENT	PREVIOUS
Nbhd	SCRAG NCK	NOTE Chapter 91 License #96-01 Expires 2094	LAND	2,953,000	2,613,400			
Infl1	DOCK		BUILDING	538,900	476,800			
N_Index	AVG		DETACHED	201,400	191,900			
			OTHER	0	0			
TOTAL			3,693,300	3,282,100				

TY	QUAL	COND	DIM/NOTE	YB	UNITS	ADJ PRICE	RCNLD
PPD	E	1.90	10 0.90		560	344.28	173,500
FLD	E	1.90	10 0.90	16X16	256	114.76	26,400
SHF	A	1.00	A 0.75	10 X 12	2021	16.42	1,500



BLDG COMMENTS

BUILDING	CD	ADJ	DESC	MEASURE	5/18/2021	TL
MODEL	1		RESIDENTIAL	LIST	5/18/2021	EST
STYLE	7	1.00	CONVENTIONAL [100%]	REVIEW	5/18/2021	TL
QUALITY	+	1.05	AVERAGE + [100%]			
FRAME	1	1.00	WOOD FRAME [100%]			

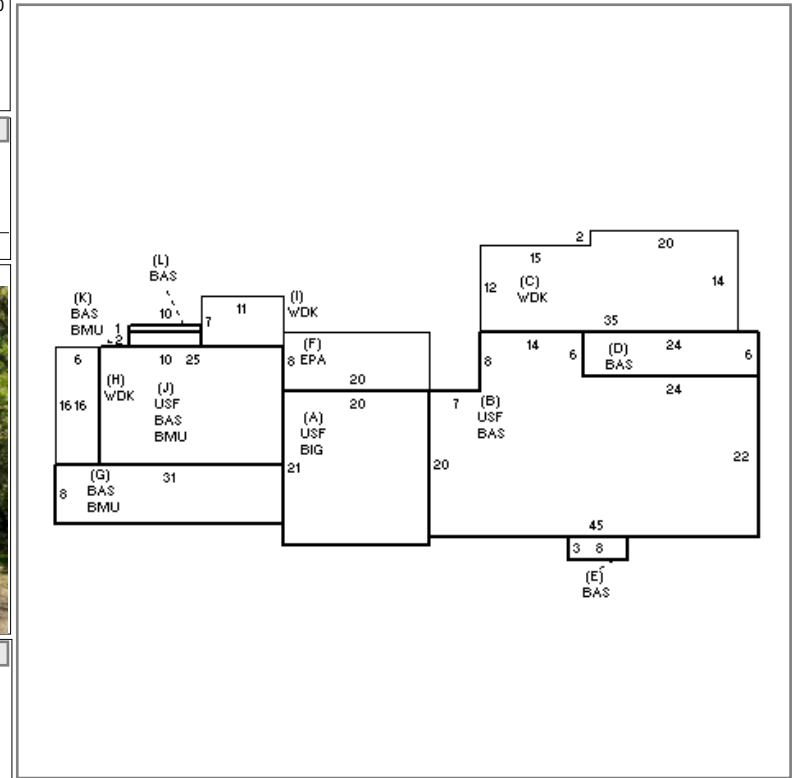

YEAR BLT	1927	SIZE ADJ	0.990
NET AREA	3,786	DETAIL ADJ	1.000
\$NLA(RCN)	\$187	OVERALL	1.020
CAPACITY		UNITS	ADJ
STORIES	2	1.00	
ROOMS	9	1.00	
BEDROOMS	6	1.00	
BATHROOMS	4	1.00	
FIXTURES	19	1.00	
GARAGE CAPACITY	1	1.00	
% BSMT FINISH	0	1.00	
# OF HALF BATHS	1	1.00	
# OF UNITS	1	1.00	

ELEMENT	CD	DESCRIPTION	ADJ
FOUNDATION	1	PIER	1.00
EXT COVER	1	WOOD SHINGLE	1.02
ROOF SHAPE	1	GABLE	1.00
ROOF COVER	1	ASPH/COMP SHIN	1.00
FLOOR COVER	1	HARDWOOD	1.02
INT. FINISH	1	PLASTER	1.00
HEATING/COOLING	5	ELECTRIC BB	0.98
FUEL SOURCE	3	ELECTRIC	1.00
USE	0		1.00

S	BAT	T	DESCRIPTION	UNITS	YB	ADJ PRICE	RCN
A	BIG	N	BUILT-IN GARAGE	420		83.13	34,915
+	USF	L	UPPER STORY FIN	1,880	1927	110.24	207,244
+	BAS	L	BASE AREA	1,906	1927	187.79	357,936
+	WDK	N	WOOD DECK	633		22.65	14,336
F	EPA	N	ENCLOSED PORCH	160		78.24	12,519
+	BMU	N	BSMT UNFINISHED	668		48.81	32,603
F12	O		FPL 1S 2OP	2		8,927.10	17,854
FIX	O		XTRA FIXTURES	14		2,257.96	31,612

TOTAL RCN	709,019
CONDITION ELEM	CD
EXTERIOR	A
INTERIOR	A
KITCHEN	A
BATHS	A
HEAT	A
ELECT	A
EFF.YR/AGE	1995 / 27
COND	24 24 %
FUNC	0
ECON	0
DEPR	24 % GD 76
RCNLD	\$538,900