

Key: 10698

Town of Bourne - Fiscal Year 2024

12/18/2023 6:02 pm SEQ #: 10.964

LEGAL

LAND

DETAILED

BUILDING

CURRENT OWNER				PARCEL ID				LOCATION			
BALL JOHN R ETUX SUZANNE F BALL PO BOX 811 CATAUMET, MA 02534				50.0-157-0				284 SCRAGGY NECK RD			
TRANSFER HISTORY				DOS	T	SALE PRICE	BK-PG (Cert)				
BALL JOHN R ETUX HACKING ROBERT M &				10/02/2007	QS	3,495,000	22379-121				
				04/22/1996	G	880,000	10160-206				

CLASS	CLASS%	DESCRIPTION			BN ID	BN	CARD	
1010	100	SINGLE FAMILY				1	1 of 1	
PMT NO	PMT DT	TY	DESC	AMOUNT	INSP	BY	1st	%
H550	06/11/2020	2	ADDITIONS				100	100
19859	09/16/2019	2	ADDITIONS	975,726	05/11/2020	RP	100	100
960180	05/06/1996	3	ALT/RENO	85,000	12/17/1996	JC	100	100
910029	02/04/1991	9	DECK	5,000	02/03/1992	HS	100	100

CD	T	AC/SF/UN	Nbhd	Infl1	N Index	ADJ BASE	SAF	Topo	Lpi	VC	CREDIT AMT	ADJ VALUE				
100	S	40,000	15	1.00	DCK	1.00	100	1.00	3,181,950	1.00	A	1.00	BSP	13.50		2,921,320
300	A	0.251	15	1.00	100	1.00	100	1.00	220,050	1.00	A	1.00	BSP	13.50		55,230

TOTAL	1.169 Acres	ZONING	1	FRNT	0	ASSESSED	CURRENT	PREVIOUS
Nbhd	SCRAG NCK	NOTE deep water access; beautiful views from outside & inside hse; Chapter 91 #82-5 Expires 2096	LAND	2,976,600	2,634,200			
Infl1	DOCK		BUILDING	2,843,500	2,516,400			
N_Index	AVG		DETACHED	206,300	196,400			
			OTHER	0	0			
		TOTAL		6,026,400	5,347,000			

TY	QUAL	COND	DIM/NOTE	YB	UNITS	ADJ PRICE	RCNLD
PPD	E	1.90	10 0.90	8X20,13X20,6	548	344.28	169,800
SHF	G	1.20	10 0.90	12X17	204	18.28	3,400
FLD	E	1.90	10 0.90	10X16(2)	320	114.76	33,100



BLDG COMMENTS

BUILDING	CD	ADJ	DESC	MEASURE	5/11/2020	RP
MODEL	1		RESIDENTIAL	LIST	5/11/2020	EST
STYLE	9	1.20	ANTIQUE [100%]	REVIEW	7/1/2021	TL
QUALITY	E+	2.75	EXCELLENT PLUS [100%]			
FRAME	1	1.00	WOOD FRAME [100%]			

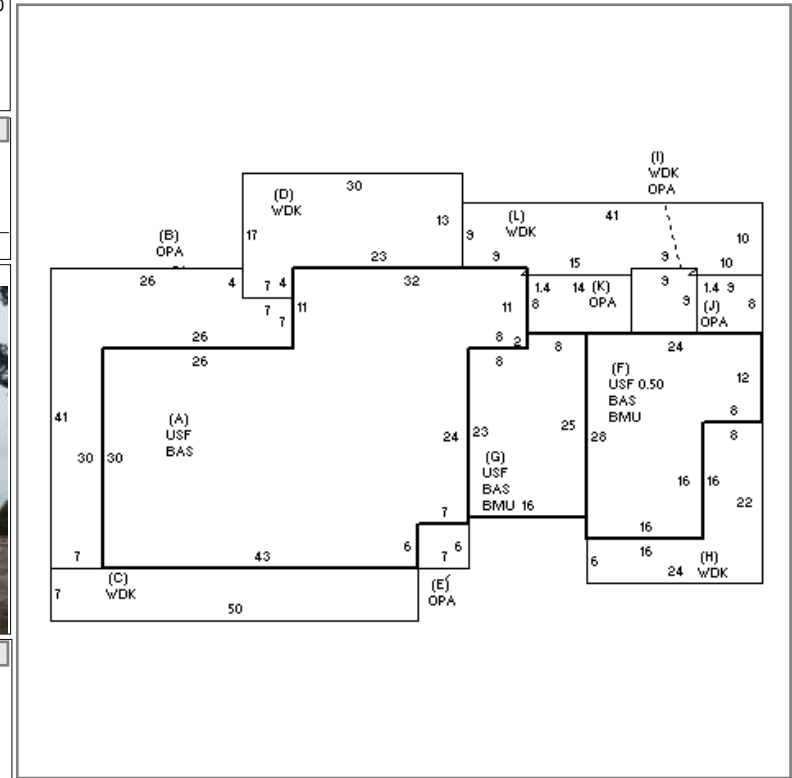

YEAR BLT	1881	SIZE ADJ	0.975	ELEMENT	CD	DESCRIPTION	ADJ	S	BAT	T	DESCRIPTION	UNITS	YB	ADJ PRICE	RCN	TOTAL RCN	2,901,494
NET AREA	5,204	DETAIL ADJ	1.000	FOUNDATION	3	FOUN. WALL	1.00	+	BAS	L	BASE AREA	2,194	1881	568.76	1,247,867		
\$NLA(RCN)	\$558	OVERALL	1.290	EXT COVER	1	WOOD SHINGLE	1.02	A	USF	L	UPPER STORY FIN	1,810	1881	299.67	542,404		
				ROOF SHAPE	1	GABLE	1.00	+	OPA	N	OPEN PORCH	852		203.56	173,432		
				ROOF COVER	1	ASP/COMP SHIN	1.00	+	WDK	N	WOOD DECK	1,514		73.88	111,855		
				FLOOR COVER	1	HARDWOOD	1.02	+	BMU	N	BSMT UNFINISHED	928		126.12	117,043		
				INT. FINISH	1	PLASTER	1.00	F	BAS	L	BASE AREA	544	2020	568.76	309,408		
				HEATING/COOLING	11	HT WATER CL AIR	1.05	+	USF	L	UPPER STORY FIN	656	2020	299.67	196,585		
				FUEL SOURCE	1	OIL	1.00		F21	O	FPL 2S 1OP	4		30,468.68	121,875		
				USE	0		1.00		FIX	O	XTRA FIXTURES	11		7,366.01	81,026		

CONDITION ELEM	CD
EXTERIOR	G
INTERIOR	G
KITCHEN	G
BATHS	G
HEAT	U
ELECT	U

EFF. YR/AGE	2017 / 5
COND	2 2 %
FUNC	0
ECON	0
DEPR	2 % GD 98
RCNLD	\$2,843,500