

Key: 107

Town of Bourne - Fiscal Year 2024

12/18/2023 6:02 pm SEQ #: 104

LEGAL LAND

CURRENT OWNER				PARCEL ID				LOCATION								
GALOVIC GARY J 18 INDIAN TRAIL SAGAMORE BEACH, MA 02562				2.3-6-0				18 INDIAN TRAIL								
TRANSFER HISTORY				DOS	T	SALE PRICE	BK-PG (Cert)									
GALOVIC GARY J				08/20/2008	QS	790,000	23111-150									
BUSKEY DAVID M TRUSTEE				08/20/2008	F	1	23111-145									
BUSKEY DAVID M TRUSTEE					XX		N/A-N/A									
CD	T	AC/SF/UN	Nbhd	Infl1	N Index	ADJ BASE	SAF	Topo	Lpi	VC	CREDIT AMT	ADJ VALUE				
100	S	26,880	1	1.00	100	1.00	100	1.00	589,250	1.35	A	1.00	BEX	2.50		489,500

CLASS	CLASS%	DESCRIPTION		BN ID	BN	CARD	
1010	100	SINGLE FAMILY			1	1 of 1	
PMT NO	PMT DT	TY	DESC	AMOUNT	INSP	BY	1st %
E-21-115	02/12/2021	3	ALT/RENO	800			100 100
15170	04/01/2015	14	SOLAR		05/05/2015		100 100
13902	12/19/2013	14	SOLAR				100 100
980016	01/08/1998	2	ADDITIONS	35,500	10/06/1999	EB	100 100
930365	07/20/1993	1	NEW CONSTRUC	200,000	11/18/1994	JS	100 100

LEGAL LAND

TOTAL	26,880 SF	ZONING	1	FRNT	120	ASSESSED	CURRENT	PREVIOUS
Nbhd	N SAG	NOTE				LAND	489,500	433,200
Infl1	AVG		BUILDING	565,600	506,400			
N_Index	AVG		DETACHED	0	0			
			OTHER	0	0			
						TOTAL	1,055,100	939,600

DETACHED

TY	QUAL	COND	DIM/NOTE	YB	UNITS	ADJ PRICE	RCNLD

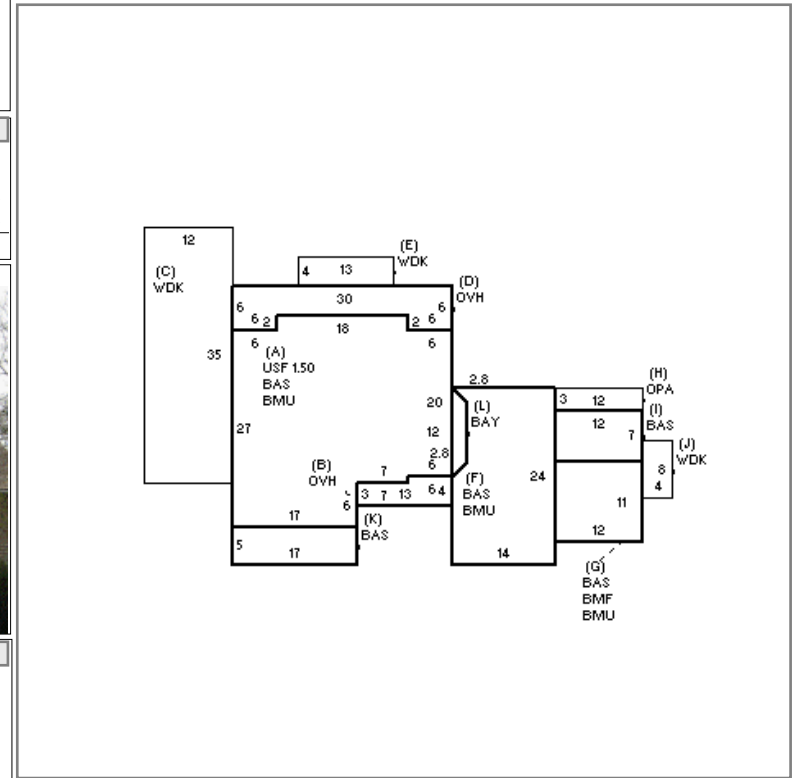

BUILDING

BUILDING	CD	ADJ	DESC	MEASURE	7/20/2021	NMP
MODEL	1		RESIDENTIAL	LIST	11/15/2011	EST
STYLE	8	1.10	CONTEMPORARY [100%]	REVIEW	4/27/2022	TL
QUALITY	+	1.05	AVERAGE + [100%]			
FRAME	1	1.00	WOOD FRAME [100%]			

BLDG COMMENTS

BUILDING

YEAR BLT	1993	SIZE ADJ	1.000	ELEMENT	CD	DESCRIPTION	ADJ	S	BAT	T	DESCRIPTION	UNITS	YB	ADJ PRICE	RCN	TOTAL RCN	665,423
NET AREA	2,751	DETAIL ADJ	1.000	FOUNDATION	4	FLR/WALL(FULL)	1.00	+	BMU	N	BSMT UNFINISHED	1,230		40.59	49,923		
\$NLA(RCN)	\$242	OVERALL	1.210	EXT COVER	1	WOOD SHINGLE	1.02	A	USF	L	UPPER STORY FIN	1,143	1993	132.09	150,980		
				ROOF SHAPE	1	GABLE	1.00	+	OVH	L	OVERHANG	189	1993	230.09	43,487		
				ROOF COVER	2	WOOD SHINGLES	1.02	+	WDK	N	WOOD DECK	504		27.14	13,677		
				FLOOR COVER	1	HARDWOOD	1.02	G	BMF	N	BSMT FINISH	132		74.24	9,799		
				INT. FINISH	2	DRYWALL	1.00	H	OPA	N	OPEN PORCH	36		103.51	3,726		
				HEATING/COOLING	11	HT WATER CL AIR	1.05	+	BAS	L	BASE AREA	1,399	1993	238.83	334,125		
				FUEL SOURCE	2	GAS	1.00	L	BAY	L	BAYWINDOW	20	1993	230.09	4,602		
				USE	0		1.00		BMG	O	BSMT GARAGE	1		9,056.10	9,056		
									F21	O	FPL 2S 1OP	1		11,191.80	11,192		
									FIX	O	XTRA FIXTURES	10		2,705.66	27,057		
									WPL	O	WHIRLPOOL	1		7,799.60	7,800		
																EFF.YR/AGE	2004 / 18
																COND	15 15 %
																FUNC	0
																ECON	0
																DEPR	15 % GD 85
																RCNLD	\$565,600