

Key: 10709

Town of Bourne - Fiscal Year 2024

12/18/2023 6:02 pm SEQ #: 10.976

LEG  
AL  
LAND

CURRENT OWNER				PARCEL ID				LOCATION			
PEARCE JOHN W ETUX KATHRYN A PEARCE PO BOX 740 CATAUMET, MA 02534				50.0-168-0				75 WINSOR RD			
TRANSFER HISTORY				DOS	T	SALE PRICE	BK-PG (Cert)				
PEARCE JOHN W ETUX				09/30/2013	QS	3,040,000	27725-292				
BURNES AMY W & ANDREW P T				12/04/1991	XX		07779-00248				

CLASS	CLASS%	DESCRIPTION			BN ID	BN	CARD	
1010	100	SINGLE FAMILY				1	1 of 1	
PMT NO	PMT DT	TY	DESC	AMOUNT	INSP	BY	1st	%
15623	07/27/2015	12	CYCLICAL		02/15/2018	DB	100	100
15009	01/07/2015	6	FENCE	46,000	07/08/2016	WFF	100	100
10709	11/14/2014	8	POOL	108,000	07/08/2016	WFF	100	100
14020	01/16/2014	4	DETACH.STRUC	65,000	07/08/2016	WFF	100	100
		2	ADDITIONS	57,500	07/08/2016	WFF	100	100

CD	T	AC/SF/UN	Nbhd	Infl1	N Index	ADJ BASE	SAF	Topo	Lpi	VC	CREDIT AMT	ADJ VALUE	
100	S	40,000	14	1.00	DCK 1.00	100	1.00	2,769,475	1.00	A	1.00	BSB 11.75	2,542,630
300	A	1,922	14	1.00	100	1.00	100	191,525	1.00	A	1.00	BSB 11.75	368,110

TOTAL	2.840 Acres	ZONING	1	FRNT	0	ASSESSED	CURRENT	PREVIOUS
Nbhd	CATAUMET	NOTE Chapter 91 License Expires 2045	LAND	2,910,700	2,575,500			
Infl1	DOCK		BUILDING	4,110,300	3,637,500			
N_Index	AVG		DETACHED	613,400	584,200			
			OTHER	0	0			
		TOTAL	7,634,400	6,797,200				

TY	QUAL	COND	DIM/NOTE	YB	UNITS	ADJ PRICE	RCNLD
PPD	S	3.00	10 0.90 5X167 + 8X15		955	543.60	467,200
IPG	S	3.00	10 0.90 18 X 32	2015	576	83.72	43,400
GUL	S	3.00	10 0.90 24 X 27	2015	648	101.40	59,100
OPS	E	1.90	10 0.90 10 X 27	2015	270	31.92	7,800
FLD	S	3.00	10 0.90 10 X 22		220	181.20	35,900

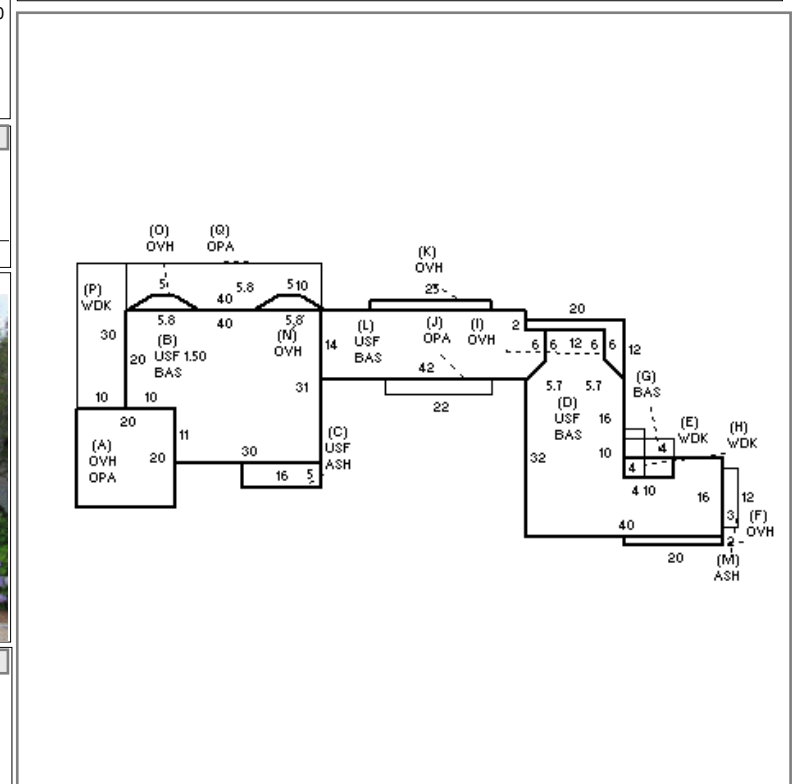

BUILDING	CD	ADJ	DESC	MEASURE	9/12/2018	BC
MODEL	1		RESIDENTIAL	LIST	9/12/2018	EST
STYLE	9	1.20	ANTIQUE [100%]	REVIEW	4/18/2019	TL
QUALITY	S	3.30	SUPERLATIVE [100%]			
FRAME	1	1.00	WOOD FRAME [100%]			

BLDG COMMENTS

DE  
TA  
CH  
ED

B  
U  
I  
L  
D  
I  
N  
G

YEAR BLT	1891	SIZE ADJ	0.970	ELEMENT	CD	DESCRIPTION	ADJ	S	BAT	T	DESCRIPTION	UNITS	YB	ADJ PRICE	RCN	TOTAL RCN	4,372,658
NET AREA	6,999	DETAIL ADJ	1.000	FOUNDATION	1	PIER	1.00	+	OPA	N	OPEN PORCH	866		243.02	210,453		
\$NLA(RCN)	\$625	OVERALL	1.290	EXT COVER	1	WOOD SHINGLE	1.02	+	BAS	L	BASE AREA	2,266	1891	679.01	1,538,648		
				ROOF SHAPE	1	GABLE	1.00	+	USF	L	UPPER STORY FIN	3,491	1891	357.76	1,248,945		
				ROOF COVER	1	ASPH/COMP SHIN	1.00	C	ASH	N	ATT SHED	80		98.48	7,879		
				FLOOR COVER	2	SOFTWOOD	1.02	+	WDK	N	WOOD DECK	380		88.20	33,517		
				INT. FINISH	1	PLASTER	1.00	+	OVH	L	OVERHANG	622	1891	747.81	465,140		
				HEATING/COOLING	11	HT WATER CL AIR	1.05	L	BAS	L	BASE AREA	620	2014	679.02	420,989		
				FUEL SOURCE	2	GAS	1.00	M	ASH	N	ATT SHED	36		102.66	3,696		
				USE	0		1.00		F21	O	FPL 2S 1OP	1		36,374.90	36,375		
									F32	O	FPL 3S 2OP	1		39,732.00	39,732		
									FIX	O	XTRA FIXTURES	36		8,793.78	316,576		
									JAC	O	JACUZZI	1		50,707.70	50,708		
																CONDITION ELEM	CD
																EXTERIOR	G
																INTERIOR	G
																KITCHEN	G
																BATHS	G
																HEAT	U
																ELECT	U
																EFF.YR/AGE	2013 / 9
																COND	6 6 %
																FUNC	0
																ECON	0
																DEPR	6 % GD 94
																RCNLD	\$4,110,300