

Key: 10721

Town of Bourne - Fiscal Year 2024

12/18/2023 6:02 pm SEQ #: 10.990

LEGAL

CURRENT OWNER				PARCEL ID				LOCATION			
DARLING ELAINE C PO BOX 678 CATAUMET, MA 02534-0678				51.0-6-0				255 SCRAGGY NECK RD			
TRANSFER HISTORY				DOS	T	SALE PRICE	BK-PG (Cert)				
DARLING ELAINE C				08/11/1997	XX		10892-308				

CLASS	CLASS%	DESCRIPTION			BN ID	BN	CARD	
1010	100	SINGLE FAMILY				1	1 of 1	
PMT NO	PMT DT	TY	DESC	AMOUNT	INSP	BY	1st	%
		13	OTHER				100	100

LAND

CD	T	AC/SF/UN	Nbhd	Infl1	N Index	ADJ BASE	SAF	Topo	Lpi	VC	CREDIT AMT	ADJ VALUE				
100	S	40,000	14	1.00	100	1.00	100	1.00	2,144,870	1.00	A	1.00	BSP	9.10		1,969,180
300	A	1.552	14	1.00	100	1.00	100	1.00	148,330	1.00	A	1.00	BSP	9.10		230,210

TOTAL	2.470 Acres	ZONING	1	FRNT	0	ASSESSED	CURRENT	PREVIOUS
Nbhd	CATAUMET	NOTE	LAND	2,199,400	1,946,100			
Infl1	AVG		BUILDING	901,900	798,100			
N_Index	AVG		DETACHED	23,800	22,600			
			OTHER	0	0			
		TOTAL		3,125,100	2,766,800			

DETAILED

TY	QUAL	COND	DIM/NOTE	YB	UNITS	ADJ PRICE	RCNLD
CTC	A	1.00	F 0.60		1	16,668.40	10,000
DGF	A	1.00	40 0.60	28X20	560	36.34	12,200
SHF	A	1.00	20 0.80	10X12	120	16.42	1,600

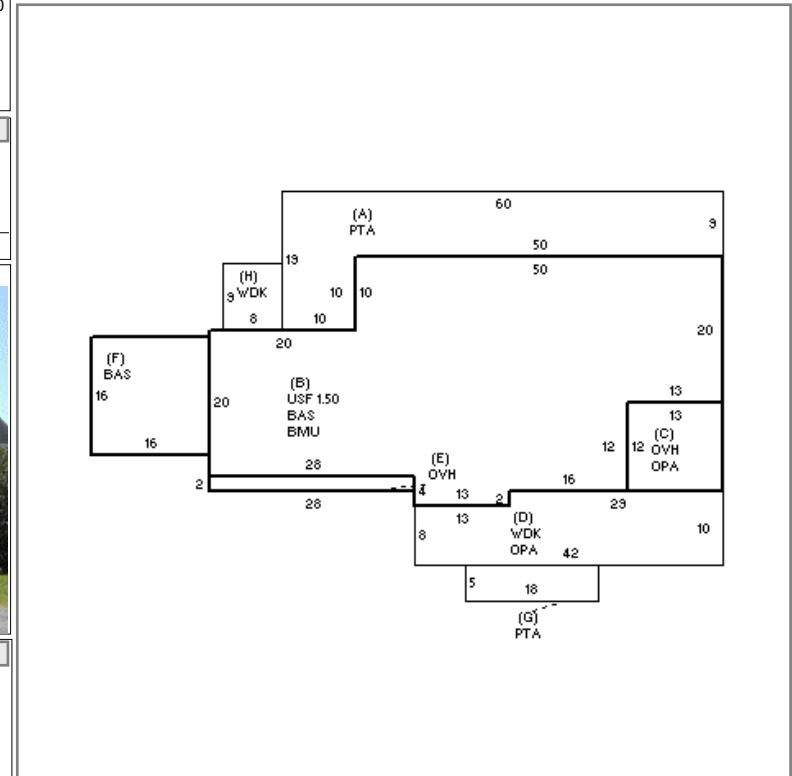

BUILDING

BUILDING	CD	ADJ	DESC	MEASURE	8/12/2021	RP
MODEL	1		RESIDENTIAL	LIST	8/12/2021	EST
STYLE	9	1.20	ANTIQUE [100%]	REVIEW	8/12/2021	RP
QUALITY	+	1.05	AVERAGE + [100%]			
FRAME	1	1.00	WOOD FRAME [100%]			

BLDG COMMENTS

G

YEAR BLT	1874	SIZE ADJ	0.975	ELEMENT	CD	DESCRIPTION	ADJ	S	BAT	T	DESCRIPTION	UNITS	YB	ADJ PRICE	RCN	TOTAL RCN	1,024,904		
NET AREA	5,103	DETAIL ADJ	1.000	FOUNDATION	4	FLR/WALL(FULL)	1.00	+	PTA	N	PATIO	730		17.54	12,804	CONDITION ELEM	CD		
\$NLA(RCN)	\$201	OVERALL	1.260	EXT COVER	1	WOOD SHINGLE	1.02	B	BMU	N	BSMT UNFINISHED	1,854		38.25	70,914	EXTERIOR	A		
				ROOF SHAPE	1	GABLE	1.00	B	USF	L	UPPER STORY FIN	2,781	1874	111.76	310,802	INTERIOR	V		
				ROOF COVER	1	ASPH/COMP SHIN	1.00	+	OPA	N	OPEN PORCH	550		75.92	41,754	KITCHEN	V		
				FLOOR COVER	1	HARDWOOD	1.02	+	OVH	L	OVERHANG	212	1874	233.60	49,524	BATHS	V		
				INT. FINISH	1	PLASTER	1.00	+	BAS	L	BASE AREA	2,110	1874	221.69	467,769	HEAT	A		
				HEATING/COOLING	2	HOT WATER	1.02	+	WDK	N	WOOD DECK	466		27.55	12,840	ELECT	A		
				FUEL SOURCE	2	GAS	1.00		F31	O	FPL 3S 1OP	2		12,928.90	25,858				
				USE	0		1.00		FIX	O	XTRA FIXTURES	9		2,746.97	24,723				
									HTB	O	HOT TUB	1		7,916.30	7,916				
																EFF.YR/AGE	2007 / 15		
																COND	12 12 %		
																FUNC	0		
																ECON	0		
																DEPR	12	% GD	88
																RCNLD	\$901,900		