

Key: 10737

Town of Bourne - Fiscal Year 2024

12/18/2023 6:02 pm SEQ #: 11.010

LEGAL

CURRENT OWNER				PARCEL ID				LOCATION				
SCHOFIELD ALLEN W & JACOB E SCHOFIELD 12 BELL RD BOURNE, MA 02532				51.0-27-0				1225 COUNTY RD				
				TRANSFER HISTORY				DOS	T	SALE PRICE	BK-PG (Cert)	
				SCHOFIELD ALLEN W & OKERHOLM JOHANNA & GATTOZZI LOUISE A				06/15/2016	QS	305,000	29727-153	
								29100-103				
								28434-289+90				

CLASS	CLASS%	DESCRIPTION		BN ID	BN	CARD		
1010	100	SINGLE FAMILY			1	1 of 1		
PMT NO	PMT DT	TY	DESC	AMOUNT	INSP	BY	1st	%
19206	03/26/2019	3	ALT/RENO	2,000			100	100
19126	02/21/2019	9	DECK	5,000			100	100
18223	03/29/2018	3	ALT/RENO	5,000	04/03/2018	BC	100	100
16802	09/19/2016	4	DETACH.STRUC	60,000	04/03/2018	BC	100	100
16200	03/23/2016	3	ALT/RENO	15,275	04/27/2016	TL	100	100

LAND

CD	T	AC/SF/UN	Nbhd	Infl1	N Index	ADJ BASE	SAF	Topo	Lpi	VC	CREDIT AMT	ADJ VALUE				
100	S	40,000	14	1.00	100	1.00	100	1.00	223,915	1.00	A	1.00	R03	0.95		205,570
300	A	0.162	14	1.00	100	1.00	100	1.00	15,485	1.00	A	1.00	R03	0.95		2,510

DETACHED

TOTAL	1.080 Acres		ZONING	1	FRNT	0	ASSESSED	CURRENT	PREVIOUS
Nbhd	CATAUMET		NOTE	LAND	208,100	184,200			
Infl1	AVG			BUILDING	309,200	273,600			
N_Index	AVG			DETACHED	48,300	46,000			
				OTHER	0	0			
				<b>TOTAL</b>	<b>565,600</b>	<b>503,800</b>			

TY	QUAL	COND	DIM/NOTE	YB	UNITS	ADJ PRICE	RCNLD	PHOTO	04/03/2018
SHF	A	1.00	40 0.60	10 X 12	120	16.42	1,200		
DGF	A	1.00	10 0.90	50 X 32	2016	32.72	47,100		

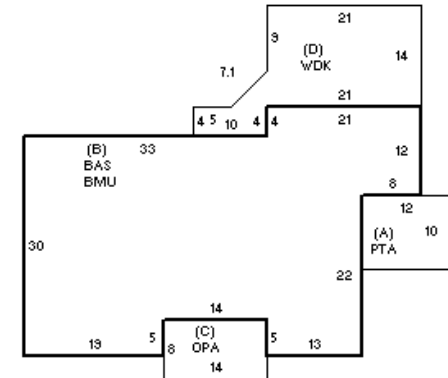

BUILDING

BUILDING	CD	ADJ	DESC	MEASURE	4/3/2018	BC
MODEL	1		RESIDENTIAL	LIST	4/3/2018	BC
STYLE	1	0.95	RANCH [100%]	REVIEW	2/3/2020	TL
QUALITY	A	1.00	AVERAGE [100%]			
FRAME	1	1.00	WOOD FRAME [100%]			

YEAR BLT	1959	SIZE ADJ	1.015	ELEMENT	CD	DESCRIPTION	ADJ	S	BAT	T	DESCRIPTION	UNITS	YB	ADJ PRICE	RCN	TOTAL RCN	368,065
NET AREA	1,458	DETAIL ADJ	1.000	FOUNDATION	4	FLR/WALL(FULL)	1.00	A	PTA	N	PATIO	120		14.94	1,793		
\$NLA(RCN)	\$252	OVERALL	1.030	EXT COVER	1	WOOD SHINGLE	1.02	B	BMU	N	BSMT UNFINISHED	1,458		33.40	48,695		
				ROOF SHAPE	2	HIP	1.02	B	BAS	L	BASE AREA	1,458	1959	191.79	279,633		
				ROOF COVER	1	ASPH/COMP SHIN	1.00	C	OPA	N	OPEN PORCH	112		71.73	8,034		
				FLOOR COVER	1	HARDWOOD	1.02	D	WDK	N	WOOD DECK	347		22.33	7,749		
				INT. FINISH	2	DRYWALL	1.00		F12	O	FPL 1S 2OP	1		8,802.70	8,803		
				HEATING/COOLING	2	HOT WATER	1.02		FIX	O	XTRA FIXTURES	6		2,226.47	13,359		
				FUEL SOURCE	1	OIL	1.00										
				USE	0		1.00										

CONDITION ELEM	CD
EXTERIOR	A
INTERIOR	A
KITCHEN	G
BATHS	G
HEAT	A
ELECT	U

EFF.YR/AGE	2003 / 19	
COND	16	16 %
FUNC	0	
ECON	0	
DEPR	16	% GD 84
RCNLD	\$309,200	