

Key: 10843

Town of Bourne - Fiscal Year 2024

12/18/2023 6:02 pm SEQ #: 11.122

LEGAL LAND

CURRENT OWNER				PARCEL ID				LOCATION								
GOULD ANNE PO BOX CATAUMET, MA 02534				51.2-27-0				1206 COUNTY RD								
TRANSFER HISTORY				DOS	T	SALE PRICE	BK-PG (Cert)									
GOULD ANNE				09/08/2022	U	599,000	35352-69									
PARADIS DONALD N				01/06/2022	QS	533,000	34809-225									
HUDSON ERIC J				08/26/2009	QS	289,900	23990-215									
CD	T	AC/SF/UN	Nbhd	Infl1	N Index	ADJ BASE	SAF	Topo	Lpi	VC	CREDIT AMT	ADJ VALUE				
100	S	7,700	14	1.00	100	1.00	100	1.00	223,915	3.98	A	1.00	R03	0.95		157,420

CLASS	CLASS%	DESCRIPTION			BN ID	BN	CARD	
1010	100	SINGLE FAMILY				1	1 of 1	
PMT NO	PMT DT	TY	DESC	AMOUNT	INSP	BY	1st	%
EXB-22-72	02/10/2022	3	ALT/RENO		02/18/2022	RP	100	100
16268	04/19/2016	3	ALT/RENO	2,173			100	100
09344	07/27/2009	3	ALT/RENO	7,600	01/08/2010	TL	100	100
03870	11/25/2003	3	ALT/RENO	14,600	06/22/2004	TL	100	100
				20,000				

LEGAL LAND

TOTAL	7,710 SF	ZONING	1	FRNT	0	ASSESSED	CURRENT	PREVIOUS
Nbhd	CATAUMET	NOTE				LAND	157,400	139,300
Infl1	AVG		BUILDING	341,600	311,600			
N_Index	AVG		DETACHED	12,200	11,600			
			OTHER	0	0			
						<b>TOTAL</b>	<b>511,200</b>	<b>462,500</b>

DETACHED

TY	QUAL	COND	DIM/NOTE	YB	UNITS	ADJ PRICE	RCNLD
DGF	V	1.30	A 0.75	14 X 22	308	52.78	12,200

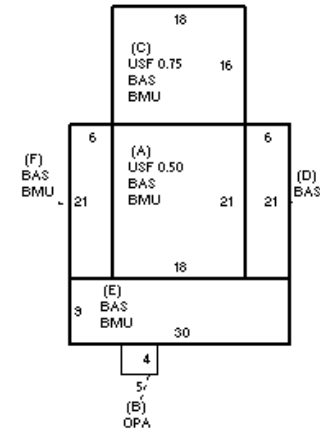

BUILDING

BUILDING	CD	ADJ	DESC	MEASURE	2/10/2022	TL
MODEL	1		RESIDENTIAL	LIST	2/10/2022	EST
STYLE	7	1.00	CONVENTIONAL [100%]	REVIEW	10/5/2023	RP
QUALITY	+	1.05	AVERAGE + [100%]			
FRAME	1	1.00	WOOD FRAME [100%]			

BLDG COMMENTS

BUILDING

YEAR BLT	1930	SIZE ADJ	1.010	ELEMENT	CD	DESCRIPTION	ADJ	S	BAT	T	DESCRIPTION	UNITS	YB	ADJ PRICE	RCN	TOTAL RCN	352,128		
NET AREA	1,593	DETAIL ADJ	1.000	FOUNDATION	4	FLR/WALL(FULL)	1.00	+	BMU	N	BSMT UNFINISHED	1,062		40.99	43,533	CONDITION ELEM	CD		
\$NLA(RCN)	\$221	OVERALL	1.060	EXT COVER	2	CLAPBOARD	1.00	A	USF	L	UPPER STORY FIN	189	1999	123.69	23,377	EXTERIOR	V		
				ROOF SHAPE	2	HIP	1.02	B	OPA	N	OPEN PORCH	20		106.85	2,137	INTERIOR	V		
				ROOF COVER	1	ASPH/COMP SHIN	1.00	C	BAS	L	BASE AREA	288	2000	215.79	62,149	KITCHEN	V		
				FLOOR COVER	1	HARDWOOD	1.02	C	USF	L	UPPER STORY FIN	216	2000	123.69	26,717	BATHS	V		
				INT. FINISH	2	DRYWALL	1.00	+	BAS	L	BASE AREA	900	1930	215.79	194,215	HEAT	A		
				HEATING/COOLING	2	HOT WATER	1.02									ELECT	A		
				FUEL SOURCE	2	GAS	1.00												
				USE	0		1.00												
																		EFF.YR/AGE	2016 / 6
																		COND	3 3 %
																		FUNC	0
																		ECON	0
																		DEPR	3 % GD 97
																		RCNLD	\$341,600