

Key: 10949

Town of Bourne - Fiscal Year 2024

12/18/2023 6:02 pm SEQ #: 11.232

LEGAL

CURRENT OWNER				PARCEL ID				LOCATION			
FOX WILLIAM K & ERIKA S FOX PO BOX 344 CATAUMET, MA 02534-0344				51.3-56-0				50 SQUETEAGUE HARBOR RD			
TRANSFER HISTORY				DOS	T	SALE PRICE	BK-PG (Cert)				
FOX WILLIAM K &				09/15/1997	J	225,000	10953-77				

CLASS	CLASS%	DESCRIPTION				BN ID	BN	CARD	
1010	100	SINGLE FAMILY					1	1 of 1	
PMT NO	PMT DT	TY	DESC	AMOUNT	INSP	BY	1st	%	

LAND

CD	T	AC/SF/UN	Nbhd	Infl1	N Index	ADJ BASE	SAF	Topo	Lpi	VC	CREDIT AMT	ADJ VALUE	
100	S	27,878	14	1.00	100	1.00	1,708,825	1.31	A	1.00	BVG	7.25	1,430,910

TOTAL	27,878 SF	ZONING	1	FRNT	0	ASSESSED	CURRENT	PREVIOUS
Nbhd	CATAUMET	NOTE	LAND	1,430,900	1,266,400			
Infl1	AVG		BUILDING	300,700	266,100			
N_Index	AVG		DETACHED	1,000	1,000			
			OTHER	0	0			
		TOTAL	1,732,600	1,533,500				

DETACHED

TY	QUAL	COND	DIM/NOTE	YB	UNITS	ADJ PRICE	RCNLD
SHF	A	1.00	40 0.60	10 X 10	100	16.90	1,000

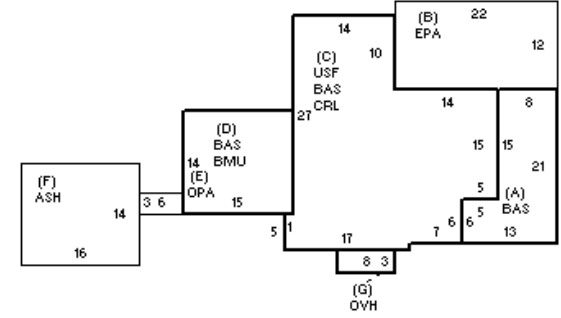

BUILDING	CD	ADJ	DESC	MEASURE	1/17/2020	TL
MODEL	1		RESIDENTIAL	LIST	1/17/2020	TL
STYLE	9	1.20	ANTIQUE [100%]	REVIEW		
QUALITY	A	1.00	AVERAGE [100%]			
FRAME	1	1.00	WOOD FRAME [100%]			

BLDG COMMENTS

BUILDING

YEAR BLT	1889	SIZE ADJ	1.010
NET AREA	1,870	DETAIL ADJ	1.000
\$NLA(RCN)	\$251	OVERALL	1.260
CAPACITY		UNITS	ADJ
STORIES	2	1.00	
ROOMS	6	1.00	
BEDROOMS	4	1.00	
BATHROOMS	2	1.00	
FIXTURES	8	1.00	
GARAGE CAPACITY	0	1.00	
% BSMT FINISH	0	1.00	
# OF HALF BATHS	0	1.00	
# OF UNITS	1	1.00	

ELEMENT	CD	DESCRIPTION	ADJ
FOUNDATION	3	FOUN. WALL	1.00
EXT COVER	1	WOOD SHINGLE	1.02
ROOF SHAPE	2	HIP	1.02
ROOF COVER	1	ASPH/COMP SHIN	1.00
FLOOR COVER	23	SOFTWOOD-W/W	1.00
INT. FINISH	1	PLASTER	1.00
HEATING/COOLING	2	HOT WATER	1.02
FUEL SOURCE	2	GAS	1.00
USE	0		1.00

S	BAT	T	DESCRIPTION	UNITS	YB	ADJ PRICE	RCN
+	BAS	L	BASE AREA	1,127	1889	244.30	275,322
B	EPA	N	ENCLOSED PORCH	264		83.02	21,917
C	CRL	N	BSMT CRAWL	719		32.69	23,505
C	USF	L	UPPER STORY FIN	719	1889	138.37	99,491
D	BMU	N	BSMT UNFINISHED	210		78.12	16,405
E	OPA	N	OPEN PORCH	18		120.97	2,177
F	ASH	N	ATT SHED	224		27.37	6,130
G	OVH	L	OVERHANG	24	1889	230.45	5,531
	F21	O	FPL 2S 1OP	1		11,210.30	11,210
	FIX	O	XTRA FIXTURES	3		2,710.20	8,131

TOTAL RCN	469,818	
CONDITION ELEM	CD	
EXTERIOR	F	
INTERIOR	F	
KITCHEN	F	
BATHS	F	
HEAT	O	
ELECT	O	
EFF.YR/AGE	1983 / 39	
COND	36	36 %
FUNC	0	
ECON	0	
DEPR	36	% GD 64
RCNLD	\$300,700	