

Key: 11003

Town of Bourne - Fiscal Year 2024

12/18/2023 6:02 pm SEQ #: 11.292

LEGAL

CURRENT OWNER							PARCEL ID				LOCATION			
KUZIRIAN ALAN M & BARBARA JEANNE KUZIRIAN PO BOX 673 CATAUMET, MA 02534							51.4-42-0				5 PARTRIDGE LN			
TRANSFER HISTORY							DOS	T	SALE PRICE		BK-PG (Cert)			
							07/30/2021	F	10 34340-185					
							03/30/2015	F	1 28768-158					
								XX	02963-0336					

CLASS	CLASS%	DESCRIPTION			BN ID	BN	CARD	
1010	100	SINGLE FAMILY				1	1 of 1	
PMT NO	PMT DT	TY	DESC	AMOUNT	INSP	BY	1st	%
07131	03/27/2007	3	ALT/RENO	35,000	11/19/2008	TL	100	100
05867	12/20/2005	4	DETACH.STRUC	4,500	02/12/2007	TL	100	100

LAND

CD	T	AC/SF/UN	Nbhd	Infl1	N Index	ADJ BASE	SAF	Topo	Lpi	VC	CREDIT AMT	ADJ VALUE				
100	S	20,835	14	1.00	100	1.00	100	1.00	294,625	1.65	A	1.00	R06	1.25		232,900

TOTAL	20,822 SF	ZONING	1	FRNT	0	ASSESSED	CURRENT	PREVIOUS
Nbhd	CATAUMET	NOTE	LAND	232,900	206,100			
Infl1	AVG		BUILDING	339,600	300,500			
N_Index	AVG		DETACHED	2,400	2,300			
			OTHER	0	0			
		TOTAL	574,900	508,900				

DETAILED

TY	QUAL	COND	DIM/NOTE	YB	UNITS	ADJ PRICE	RCNLD
SHF	A	1.00	10 0.90	12 X 14	168	15.95	2,400

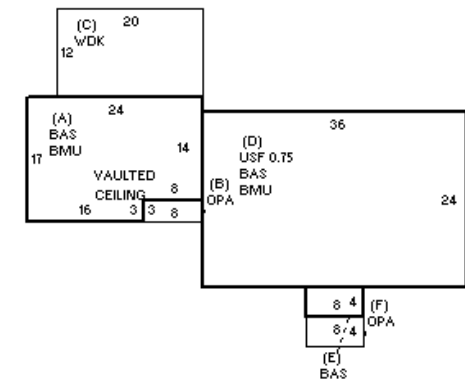
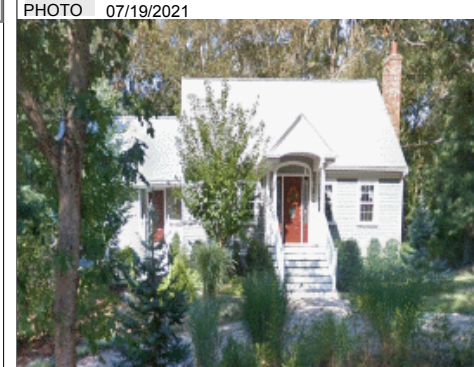

BUILDING	CD	ADJ	DESC	MEASURE	7/19/2021	RP
MODEL	1		RESIDENTIAL	LIST	7/19/2021	EST
STYLE	4	1.05	CAPE [100%]	REVIEW	7/19/2021	RP
QUALITY	A	1.00	AVERAGE [100%]			
FRAME	1	1.00	WOOD FRAME [100%]			

BLDG COMMENTS

BUILDING

YEAR BLT	1977	SIZE ADJ	1.010	ELEMENT	CD	DESCRIPTION	ADJ	S	BAT	T	DESCRIPTION	UNITS	YB	ADJ PRICE	RCN	TOTAL RCN	441,054		
NET AREA	1,928	DETAIL ADJ	1.000	FOUNDATION	4	FLR/WALL(FULL)	1.00	+	BMU	N	BSMT UNFINISHED	1,248		36.14	45,100	CONDITION ELEM	CD		
\$NLA(RCN)	\$229	OVERALL	1.120	EXT COVER	1	WOOD SHINGLE	1.02	+	OPA	N	OPEN PORCH	56		86.70	4,855	EXTERIOR	A		
				ROOF SHAPE	1	GABLE	1.00	C	WDK	N	WOOD DECK	240		29.30	7,032	INTERIOR	A		
				ROOF COVER	1	ASPH/COMP SHIN	1.00	D	USF	L	UPPER STORY FIN	648	1977	123.00	79,703	KITCHEN	A		
				FLOOR COVER	13	HARDWOOD-W/W	1.00	+	BAS	L	BASE AREA	1,280	1977	212.65	272,186	BATHS	A		
				INT. FINISH	2	DRYWALL	1.00		BMG	O	BSMT GARAGE	1		8,063.20	8,063	HEAT	A		
				HEATING/COOLING	11	HT WATER CL AIR	1.05		F21	O	FPL 2S 1OP	1		9,964.70	9,965	ELECT	A		
				FUEL SOURCE	2	GAS	1.00		FIX	O	XTRA FIXTURES	4		2,408.90	9,636				
				USE	0		1.00		MST	O	MAS/METAL STACK	1		4,514.60	4,515				
				CAPACITY		UNITS	ADJ											EFF.YR/AGE	1996 / 26
				STORIES		1.75	1.00											COND	23 23 %
				ROOMS		6	1.00											FUNC	0
				BEDROOMS		3	1.00											ECON	0
				BATHROOMS		2	1.00											DEPR	23 % GD 77
				FIXTURES		9	1.00											RCNLD	\$339,600
				GARAGE CAPACITY		1	1.00												
				% BSMT FINISH		0	1.00												
				# OF HALF BATHS		0	1.00												
				# OF UNITS		1	1.00												