

Key: 11053

Town of Bourne - Fiscal Year 2024

12/18/2023 6:02 pm SEQ #: 11,343

LEGALS

CURRENT OWNER		PARCEL ID		LOCATION	
MAGUIRE EDWARD J & SANDRA J MAGUIRE PO BOX 452 CATAUMET, MA 02534-0452		51.4-92-0		6 SANDPIPER LN	
TRANSFER HISTORY		DOS	T	SALE PRICE	BK-PG (Cert)
MAGUIRE EDWARD J &		04/21/1981	F		1 (85168)

CLASS	CLASS%	DESCRIPTION			BN ID	BN	CARD
1010	100	SINGLE FAMILY				1	1 of 1
PMT NO	PMT DT	TY	DESC	AMOUNT	INSP	BY	1st %

LAND

CD	T	AC/SF/UN	Nbhd	Infl1	N Index	ADJ BASE	SAF	Topo	Lpi	VC	CREDIT AMT	ADJ VALUE					
100	S	20,468	14	1.00	100	1.00	100	1.00	294,625	1.68	A	1.00	R06	1.25			232,180

TOTAL	20,473 SF	ZONING	1	FRNT	0	ASSESSED	CURRENT	PREVIOUS
Nbhd	CATAUMET	NOTE	LAND	232,200	205,500			
Infl1	AVG		BUILDING	389,000	344,200			
N_Index	AVG		DETACHED	0	0			
			OTHER	0	0			
			TOTAL	621,200	549,700			

DETAILED

TY	QUAL	COND	DIM/NOTE	YB	UNITS	ADJ PRICE	RCNLD	PHOTO
								08/08/2008



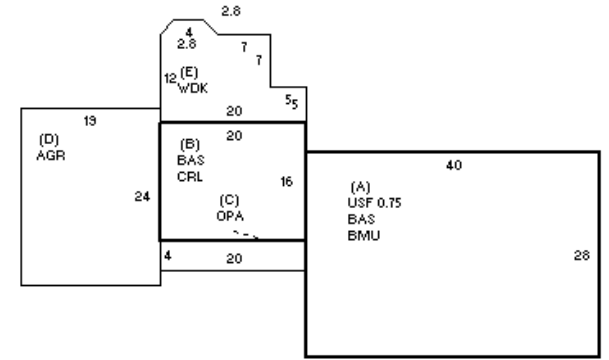

BUILDING

BUILDING	CD	ADJ	DESC	MEASURE	8/7/2008	SAL
MODEL	1		RESIDENTIAL	LIST	8/7/2008	EST
STYLE	4	1.05	CAPE [100%]	REVIEW	8/12/2008	KEO
QUALITY	A	1.00	AVERAGE [100%]			
FRAME	1	1.00	WOOD FRAME [100%]			

YEAR BLT	1975	SIZE ADJ	1.005	ELEMENT	CD	DESCRIPTION	ADJ	S	BAT	T	DESCRIPTION	UNITS	YB	ADJ PRICE	RCN	TOTAL RCN	505,171
NET AREA	2,280	DETAIL ADJ	1.000	FOUNDATION	4	FLR/WALL(FULL)	1.00	A	BMU	N	BSMT UNFINISHED	1,120		39.95	44,739		
\$NLA(RCN)	\$222	OVERALL	1.090	EXT COVER	1	WOOD SHINGLE	1.02	+	BAS	L	BASE AREA	1,440	1975	200.96	289,389		
				ROOF SHAPE	1	GABLE	1.00	A	USF	L	UPPER STORY FIN	840	1975	117.93	99,057		
				ROOF COVER	1	ASPH/COMP SHIN	1.00	B	CRL	N	BSMT CRAWL	320		37.53	12,009		
				FLOOR COVER	35	WW-VINYL	1.00	C	OPA	N	OPEN PORCH	80		78.72	6,298		
				INT. FINISH	2	DRYWALL	1.00	D	AGR	N	ATT GARAGE	456		67.70	30,873		
				HEATING/COOLING	2	HOT WATER	1.02	E	WDK	N	WOOD DECK	217		28.37	6,156		
				FUEL SOURCE	2	GAS	1.00		F21	O	FPL 2S 1OP	1		9,649.80	9,650		
				USE	0		1.00		FIX	O	XTRA FIXTURES	3		2,332.93	6,999		

TOTAL RCN	505,171
CONDITION ELEM	CD
EXTERIOR	A
INTERIOR	A
KITCHEN	A
BATHS	A
HEAT	A
ELECT	A
EFF.YR/AGE	1996 / 26
COND	23 23 %
FUNC	0
ECON	0
DEPR	23 % GD 77
RCNLD	\$389,000