

Key: 11287

Town of Bourne - Fiscal Year 2024

12/18/2023 6:02 pm SEQ #: 11.597

LEG  
A  
L  
  
L  
A  
N  
D

CURRENT OWNER				PARCEL ID				LOCATION								
GRYGENT EDWARD J PO BOX 712 CATAUMET, MA 02534				55.0-14-0				29 SANDERLING DR								
TRANSFER HISTORY				DOS	T	SALE PRICE	BK-PG (Cert)									
GRYGENT EDWARD J				07/12/2016	F	10	29789-212									
GRYGENT EDWARD J ETUX				11/03/2014	F	10	28484-276									
GRYGENT ESTELLE N & EDWAR				04/30/2010	F	10	24519-182									
CD	T	AC/SF/UN	Nbhd	Infl1	N Index	ADJ BASE	SAF	Topo	Lpi	VC	CREDIT AMT	ADJ VALUE				
100	S	14,120	14	1.00	100	1.00	100	1.00	294,625	2.30	A	1.00	R06	1.25		219,720
300	A	0.200	14	1.00	100	1.00	100	1.00	20,375	1.00	OS	1.00	R06	1.25		4,080

CLASS	CLASS%	DESCRIPTION			BN ID	BN	CARD	
1010	100	SINGLE FAMILY				1	1 of 1	
PMT NO	PMT DT	TY	DESC	AMOUNT	INSP	BY	1st	%
10244	05/13/2010	2	ADDITIONS	35,000	03/09/2016	SW	100	100
05218	04/12/2005	9	DECK		03/07/2006	TL	100	100
04598	08/09/2004	2	ADDITIONS	65,100	03/07/2006	TL	100	100
03900	12/08/2003	4	DETACH.STRUC		09/10/2004	JS	100	100

D  
E  
T  
A  
C  
H  
E  
D

TOTAL	14,113 SF	ZONING	1	FRNT	0	ASSESSED	CURRENT	PREVIOUS
Nbhd	CATAUMET	N O T E	MAP 54 PARCELS 67-68-77 MAP 55 PARCELS 22 & 28			LAND	223,800	198,100
Infl1	AVG		LAND	372,900	329,900			
N_Index	AVG		DETACHED	1,500	1,400			
					OTHER	0	0	
					TOTAL	598,200	529,400	

TY	QUAL	COND	DIM/NOTE	YB	UNITS	ADJ PRICE	RCNLD	PHOTO	03/15/2016
SHF	A	1.00	10 0.90	10 X 10		16.90	1,500		

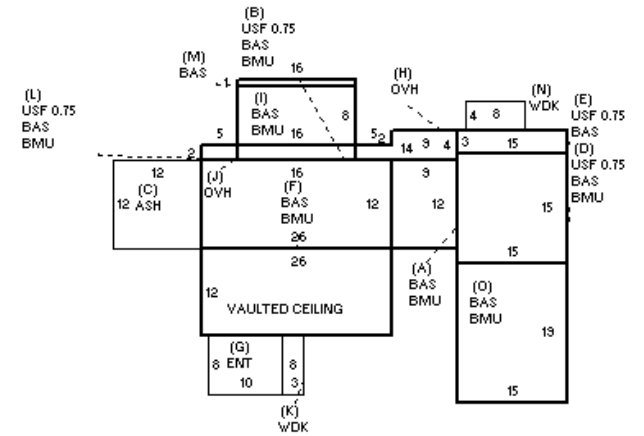

B  
U  
I  
L  
D  
I  
N  
G

BUILDING	CD	ADJ	DESC	MEASURE	3/9/2016	SW
MODEL	1		RESIDENTIAL	LIST	3/7/2006	TL
STYLE	4	1.05	CAPE [100%]	REVIEW	1/8/2018	TL
QUALITY	A	1.00	AVERAGE [100%]			
FRAME	1	1.00	WOOD FRAME [100%]			

BLDG COMMENTS

YEAR BLT	1979	SIZE ADJ	1.010	ELEMENT	CD	DESCRIPTION	ADJ	S	BAT	T	DESCRIPTION	UNITS	YB	ADJ PRICE	RCN	TOTAL RCN	471,967
NET AREA	1,980	DETAIL ADJ	1.000	FOUNDATION	4	FLR/WALL(FULL)	1.00	+	BMU	N	BSMT UNFINISHED	1,402		35.82	50,213	CONDITION ELEM	CD
\$NLA(RCN)	\$238	OVERALL	1.110	EXT COVER	1	WOOD SHINGLE	1.02	+	USF	L	UPPER STORY FIN	461	1979	123.36	56,868	EXTERIOR	A
				ROOF SHAPE	1	GABLE	1.00	C	ASH	N	ATT SHED	144		25.99	3,742	INTERIOR	A
				ROOF COVER	1	ASPH/COMP SHIN	1.00	+	BAS	L	BASE AREA	1,178	1979	205.67	242,280	KITCHEN	A
				FLOOR COVER	1	HARDWOOD	1.02	G	ENT	N	ENCLOSED ENTRY	80		67.35	5,388	BATHS	A
				INT. FINISH	2	DRYWALL	1.00	+	OVH	L	OVERHANG	56	1979	203.04	11,370	HEAT	A
				HEATING/COOLING	2	HOT WATER	1.02	+	WDK	N	WOOD DECK	56		60.16	3,369	ELECT	A
				FUEL SOURCE	1	OIL	1.00	O	BAS	L	BASE AREA	285	2010	205.67	58,616		
				USE	0		1.00		BMF	N	BSMT FINISH	488		49.12	23,970		
									F11	O	FPL 1S IOP	1		8,989.00	8,989	EFF.YR/AGE	1998 / 24
									FIX	O	XTRA FIXTURES	3		2,387.57	7,163	COND	21 21 %
																FUNC	0
																ECON	0
																DEPR	21 % GD 79
																RCNLD	\$372,900