

Key: 1149

Town of Bourne - Fiscal Year 2024

12/18/2023 6:02 pm SEQ #: 1.158

LEGALS

LAND

DETACHED

BUILDING

CURRENT OWNER				PARCEL ID				LOCATION			
SEXTON PAUL & THERESA TRS SEXTON FAMILY TRUST 8 SIR LANCELOT DR BUZZARDS BAY, MA 02532				6.0-229-0				8 SIR LANCELOT DR			
TRANSFER HISTORY				DOS	T	SALE PRICE	BK-PG (Cert)				
SEXTON PAUL & THERESA TRS				04/26/2022	F	100	35073-147				
SEXTON PAUL F ETUX				01/14/2002	F	100	14697-146				
SEXTON PAUL F				02/10/1999	X		12056-127				

CLASS	CLASS%	DESCRIPTION			BN ID	BN	CARD	
1010	100	SINGLE FAMILY				1	1 of 1	
PMT NO	PMT DT	TY	DESC	AMOUNT	INSP	BY	1st	%
11407	07/26/2011	12	CYCLICAL		02/23/2018	TL	100	100
11398	07/12/2011	2	ADDITIONS	28,500	01/12/2012		100	100
02156	03/27/2002	4	DETACH.STRUC	365	01/12/2012		100	100
980452	08/04/1998	4	DETACH.STRUC	19,183	10/04/2006	JS	100	100
		9	DECK	1,650	01/19/1999	JS	100	100

CD	T	AC/SF/UN	Nbhd	Infl1	N Index	ADJ BASE	SAF	Topo	Lpi	VC	CREDIT AMT	ADJ VALUE				
100	S	18,000	3	1.00	100	1.00	100	1.00	212,130	1.87	A	1.00	R05	0.90		163,680

TOTAL	17,990 SF	ZONING	2	FRNT	150	ASSESSED	CURRENT	PREVIOUS
Nbhd	BDALE	NOTE	LAND	163,700	161,000			
Infl1	AVG		BUILDING	404,000	361,500			
N_Index	AVG		DETACHED	0	0			
			OTHER	0	0			
TOTAL			567,700	522,500				

TY	QUAL	COND	DIM/NOTE	YB	UNITS	ADJ PRICE	RCNLD
SHF	A	1.00	10 0.90 8 X 10			0.00	



BUILDING	CD	ADJ	DESC	MEASURE	2/23/2018	TL
MODEL	1		RESIDENTIAL	LIST	2/23/2018	EST
STYLE	5	1.00	COLONIAL [100%]	REVIEW	2/23/2018	TL
QUALITY	A	1.00	AVERAGE [100%]			
FRAME	1	1.00	WOOD FRAME [100%]			

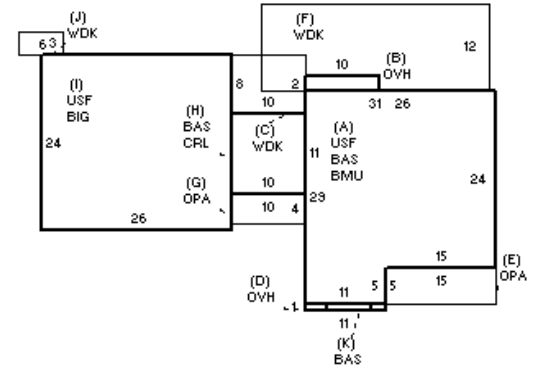

YEAR BLT	1997	SIZE ADJ	1.005
NET AREA	2,129	DETAIL ADJ	1.000
\$NLA(RCN)	\$213	OVERALL	1.060

ELEMENT	CD	DESCRIPTION	ADJ
FOUNDATION	4	FLR/WALL(FULL)	1.00
EXT COVER	1	WOOD SHINGLE	1.02
ROOF SHAPE	1	GABLE	1.00
ROOF COVER	1	ASPH/COMP SHIN	1.00
FLOOR COVER	1	HARDWOOD	1.02
INT. FINISH	2	DRYWALL	1.00
HEATING/COOLING	2	HOT WATER	1.02
FUEL SOURCE	2	GAS	1.00
USE	0		1.00

S	BAT	T	DESCRIPTION	UNITS	YB	ADJ PRICE	RCN
A	BMU	N	BSMT UNFINISHED	679		49.04	33,296
A	USF	L	UPPER STORY FIN	679	1997	110.76	75,204
+	OVH	L	OVERHANG	31	1997	192.92	5,981
+	WDK	N	WOOD DECK	470		22.75	10,695
+	OPA	N	OPEN PORCH	115		73.09	8,405
H	CRL	N	BSMT CRAWL	110		36.49	4,014
I	BIG	N	BUILT-IN GARAGE	624		78.56	49,024
I	USF	L	UPPER STORY FIN	624	2011	110.76	69,112
+	BAS	L	BASE AREA	795	1997	219.74	174,695
	FIX	O	XTRA FIXTURES	8		2,268.69	18,150
	KIT	O	EXTRA KITCHEN	1		5,351.00	5,351

TOTAL RCN	453,927
CONDITION ELEM	CD
EXTERIOR	A
INTERIOR	A
KITCHEN	G
BATHS	G
HEAT	A
ELECT	A
EFF.YR/AGE	2008 / 14
COND	11 11 %
FUNC	0
ECON	0
DEPR	11 % GD 89
RCNLD	\$404,000