

Key: 1173

Town of Bourne - Fiscal Year 2024

12/18/2023 6:02 pm SEQ #: 1.182

LEGAL

CURRENT OWNER								PARCEL ID				LOCATION			
DECOLTE ROBERT B & TANYA A 64 WINSTON AVENUE BOURNE, MA 02532								6.0-253-0				64 WINSTON AVE			
TRANSFER HISTORY								DOS	T	SALE PRICE	BK-PG (Cert)				
DECOLTE ROBERT B & TANYA								07/18/2019	QS	532,500	32163-77				
RENOVESTORS CORP								07/10/2018	F	100	31392-287				
SCAGNOLATO LUIZ H								03/21/2018	F	100	31148-332				

CLASS	CLASS%	DESCRIPTION			BN ID	BN	CARD	
1010	100	SINGLE FAMILY				1	1 of 1	
PMT NO	PMT DT	TY	DESC	AMOUNT	INSP	BY	1st	%
EXB-22-870	12/30/2022	3	ALT/RENO	19,000			100	100
EXB-20-192	08/14/2020	15	INSULATE/WEA	8,423	03/20/2018	TL	100	100
17607	08/02/2017	3	ALT/RENO	20,000	05/12/2015	TL	100	100
		13	OTHER				100	100
03241	04/29/2003	2	ADDITIONS		06/30/2004	JS	100	100

LAND

CD	T	AC/SF/UN	Nbhd	Infl1	N Index	ADJ BASE	SAF	Topo	Lpi	VC	CREDIT AMT	ADJ VALUE
100	S	43,560	3	1.00	100	212,130	0.94	A	1.00	R05	0.90	199,780

TOTAL	43,560 SF	ZONING	2	FRNT	139	ASSESSED	CURRENT	PREVIOUS
Nbhd	BDALE	NOTE	LAND	199,800	196,500			
Infl1	AVG		BUILDING	640,600	573,100			
N_Index	AVG		DETACHED	0	0			
			OTHER	0	0			
			<b>TOTAL</b>	<b>840,400</b>	<b>769,600</b>			

DETACHED

TY	QUAL	COND	DIM/NOTE	YB	UNITS	ADJ PRICE	RCNLD	PHOTO	03/20/2018
									

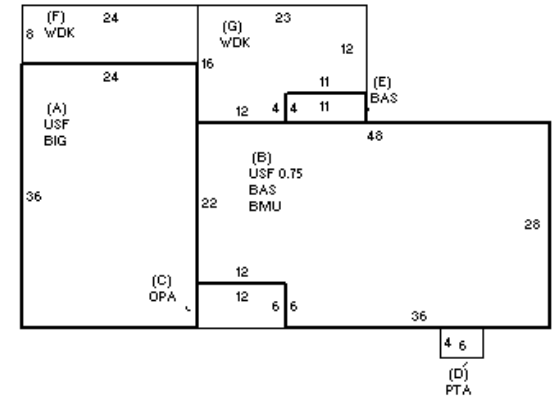

BUILDING

BUILDING	CD	ADJ	DESC	MEASURE	3/20/2018	TL
MODEL	1		RESIDENTIAL	LIST	3/20/2018	EST
STYLE	4	1.05	CAPE [100%]	REVIEW	3/20/2018	TL
QUALITY	G	1.10	GOOD [100%]			
FRAME	1	1.00	WOOD FRAME [100%]			

BLDG COMMENTS

INDIN

YEAR BLT	1999	SIZE ADJ	0.995	ELEMENT	CD	DESCRIPTION	ADJ	S	BAT	T	DESCRIPTION	UNITS	YB	ADJ PRICE	RCN	TOTAL RCN	711,731
NET AREA	3,134	DETAIL ADJ	1.000	FOUNDATION	4	FLR/WALL(FULL)	1.00	A	BIG	N	BUILT-IN GARAGE	864		84.27	72,808		
\$NLA(RCN)	\$227	OVERALL	1.100	EXT COVER	4	VINYL	1.00	+	USF	L	UPPER STORY FIN	1,818	1999	125.17	227,563		
				ROOF SHAPE	1	GABLE	1.00	B	BMU	N	BSMT UNFINISHED	1,272		38.46	48,924		
				ROOF COVER	1	ASPH/COMP SHIN	1.00	C	OPA	N	OPEN PORCH	72		92.27	6,643		
				FLOOR COVER	1	HARDWOOD	1.02	D	PTA	N	PATIO	24		20.32	488		
				INT. FINISH	2	DRYWALL	1.00	+	BAS	L	BASE AREA	1,316	1999	226.32	297,838		
				HEATING/COOLING	9	WARM-COOL AIR	1.03	+	WDK	N	WOOD DECK	516		25.72	13,270		
				FUEL SOURCE	2	GAS	1.00		FIX	O	XTRA FIXTURES	10		2,563.93	25,639		
				USE	0		1.00		GFP	O	GAS FIREPLACE	1		7,705.30	7,705		
									KIT	O	EXTRA KITCHEN	1		6,047.40	6,047		
									MST	O	MAS/METAL STACK	1		4,805.00	4,805		

CONDITION ELEM	CD
EXTERIOR	G
INTERIOR	G
KITCHEN	G
BATHS	G
HEAT	A
ELECT	A

EFF.YR/AGE	2009 / 13
COND	10 10 %
FUNC	0
ECON	0
DEPR	10 % GD 90
RCNLD	\$640,600