

Key: 1271

Town of Bourne - Fiscal Year 2024

12/18/2023 6:02 pm SEQ #: 1.280

LEGALS

CURRENT OWNER				PARCEL ID				LOCATION			
NEMETH PATRICIA A TRS C/O MAY THOMAS R & 17 NOREAST DR SAGAMORE BEACH, MA 02562				7.0-82-0				17 NOREAST DR			
TRANSFER HISTORY				DOS	T	SALE PRICE	BK-PG (Cert)				
MAY THOMAS R & NEMETH PATRICIA A TRS				11/03/2023	QS	830,000	36071-3				
NEMETH PATRICIA A				06/06/2017	F	1	30538-127				
				05/05/2017	QS	540,000	30468-102				

CLASS	CLASS%	DESCRIPTION			BN ID	BN	CARD	
1010	100	SINGLE FAMILY				1	1 of 1	
PMT NO	PMT DT	TY	DESC	AMOUNT	INSP	BY	1st	%
990660	10/28/1999	12	CYCLICAL		01/26/2018	TL	100	100
		1	NEW CONSTRUC	130,000	04/12/2002	TL	100	100

LAND

CD	T	AC/SF/UN	Nbhd	Infl1	N Index	ADJ BASE	SAF	Topo	Lpi	VC	CREDIT AMT	ADJ VALUE
100	S	15,265	1	1.00	100	1.00	100	1.00			259,270	195,330
							2.15	A	1.00	R04	1.10	

DETACHED

TOTAL	15,246 SF	ZONING	1	FRNT	120	ASSESSED	CURRENT	PREVIOUS
Nbhd	N SAG	NOTE				LAND	195,300	172,900
Infl1	AVG		LAND	607,700	544,300			
N_Index	AVG		BUILDING	0	0			
			DETACHED	0	0			
						OTHER	0	0
						TOTAL	803,000	717,200

TY	QUAL	COND	DIM/NOTE	YB	UNITS	ADJ PRICE	RCNLD	PHOTO	01/29/2018
									

BLDG COMMENTS

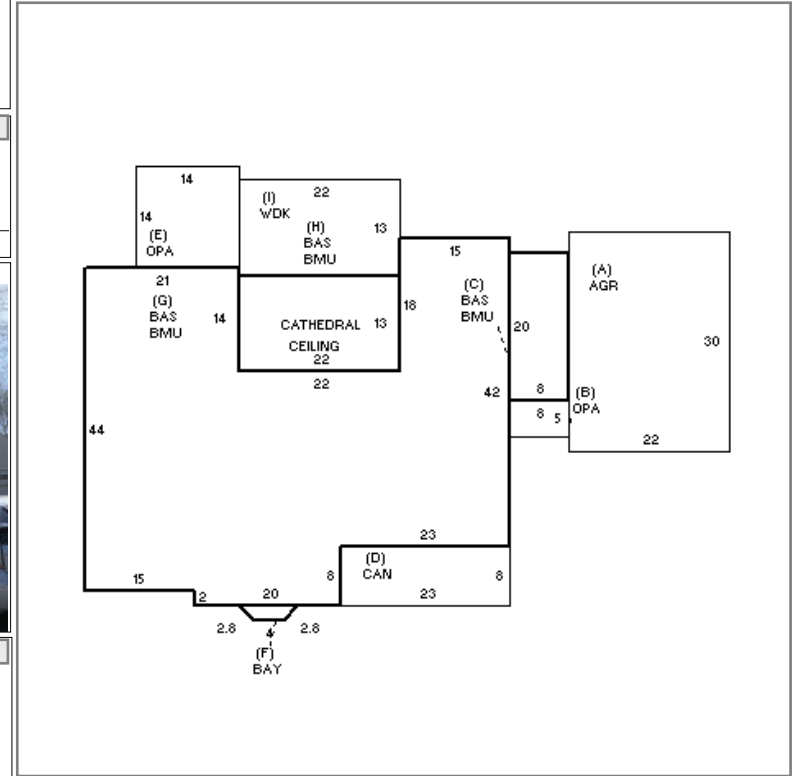

BUILDING

BUILDING	CD	ADJ	DESC	MEASURE	12/17/2021	NMP
MODEL	1		RESIDENTIAL	LIST	1/26/2018	TL
STYLE	4	1.05	CAPE [100%]	REVIEW	8/28/2019	RP
QUALITY	G	1.10	GOOD [100%]			
FRAME	1	1.00	WOOD FRAME [100%]			

YEAR BLT	2000	SIZE ADJ	1.000	ELEMENT	CD	DESCRIPTION	ADJ	S	BAT	T	DESCRIPTION	UNITS	YB	ADJ PRICE	RCN	TOTAL RCN	732,222
NET AREA	2,664	DETAIL ADJ	1.000	FOUNDATION	4	FLR/WALL(FULL)	1.00	A	AGR	N	ATT GARAGE	660		71.62	47,271		
\$NLA(RCN)	\$275	OVERALL	1.120	EXT COVER	1	WOOD SHINGLE	1.02	+	OPA	N	OPEN PORCH	236		72.51	17,111		
				ROOF SHAPE	1	GABLE	1.00	+	BMU	N	BSMT UNFINISHED	2,652		33.88	89,846		
				ROOF COVER	1	ASPH/COMP SHIN	1.00	+	BAS	L	BASE AREA	2,652	2000	202.59	537,265		
				FLOOR COVER	1	HARDWOOD	1.02	D	CAN	N	CANOPY	184		14.54	2,676		
				INT. FINISH	2	DRYWALL	1.00	F	BAY	L	BAYWINDOW	12	2000	223.09	2,677		
				HEATING/COOLING	9	WARM-COOL AIR	1.03	I	WDK	N	WOOD DECK	286		31.91	9,125		
				FUEL SOURCE	2	GAS	1.00	FIX	O	XTRA FIXTURES	7			2,623.63	18,365		
				USE	0		1.00	GFP	O	GAS FIREPLACE	1			7,884.80	7,885		

CONDITION ELEM	CD
EXTERIOR	A
INTERIOR	A
KITCHEN	A
BATHS	A
HEAT	A
ELECT	A

EFF.YR/AGE	2002 / 20
COND	17 17 %
FUNC	0
ECON	0
DEPR	17 % GD 83

RCNLD	\$607,700
-------	-----------