

Key: 1361

Town of Bourne - Fiscal Year 2024

12/18/2023 6:02 pm SEQ #: 1.366

LEGALS

CURRENT OWNER				PARCEL ID				LOCATION			
CARLSON JILL PO BOX 1323 SAGAMORE BEACH, MA 02562				7.1-43-0				6 PLYMOUTH HEIGHTS RD			
TRANSFER HISTORY				DOS	T	SALE PRICE	BK-PG (Cert)				
CARLSON JILL				10/28/2021	QS	660,000	(228047)				
HARTLEY DIANE P TR OF				08/15/1989	O	199,900	(119054)				

CLASS	CLASS%	DESCRIPTION			BN ID	BN	CARD	
1010	100	SINGLE FAMILY				1	1 of 1	
PMT NO	PMT DT	TY	DESC	AMOUNT	INSP	BY	1st	%
18732	08/27/2018	3	ALT/RENO	12,281	10/03/2019	TL	100	100
15527	07/06/2015	15	INSULATE/WEA	300			100	100
890015	01/10/1989	1	NEW CONSTRUC	100,000	04/20/1990	PR	100	100

LAND

CD	T	AC/SF/UN	Nbhd	Infl1	N Index	ADJ BASE	SAF	Topo	Lpi	VC	CREDIT AMT	ADJ VALUE					
100	S	29,617	1	1.00	100	1.00	100	1.00	259,270	1.25	A	1.00	R04	1.10			220,100

TOTAL	29,621 SF	ZONING	1	FRNT	125	ASSESSED	CURRENT	PREVIOUS
Nbhd	N SAG	NOTE	LAND	220,100	194,800			
Infl1	AVG		BUILDING	445,800	394,500			
N_Index	AVG		DETACHED	0	0			
			OTHER	0	0			
			TOTAL	665,900	589,300			

DETACHED

TY	QUAL	COND	DIM/NOTE	YB	UNITS	ADJ PRICE	RCNLD

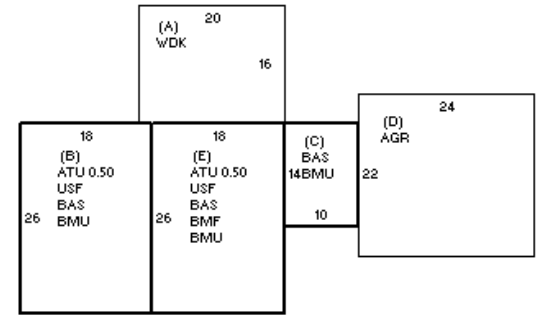

BUILDING

BUILDING	CD	ADJ	DESC	MEASURE	1/5/2022	NMP
MODEL	1		RESIDENTIAL	LIST	2/18/2022	EST
STYLE	5	1.00	COLONIAL [100%]	REVIEW	2/18/2022	RP
QUALITY	A	1.00	AVERAGE [100%]			
FRAME	1	1.00	WOOD FRAME [100%]			

BLDG COMMENTS

G

YEAR BLT	1989	SIZE ADJ	1.005	ELEMENT	CD	DESCRIPTION	ADJ	S	BAT	T	DESCRIPTION	UNITS	YB	ADJ PRICE	RCN	TOTAL RCN	479,350													
NET AREA	2,012	DETAIL ADJ	1.000	FOUNDATION	4	FLR/WALL(FULL)	1.00	A	WDK	N	WOOD DECK	320		22.97	7,350															
\$NLA(RCN)	\$238	OVERALL	1.070	EXT COVER	1	WOOD SHINGLE	1.02	+	BMU	N	BSMT UNFINISHED	1,076		39.21	42,192															
				ROOF SHAPE	1	GABLE	1.00	+	BAS	L	BASE AREA	1,076	1989	206.43	222,119															
				ROOF COVER	1	ASPH/COMP SHIN	1.00	+	USF	L	UPPER STORY FIN	936	1989	115.76	108,635															
				FLOOR COVER	13	HARDWOOD-W/W	1.00	B	ATU	N	ATTIC UNF	234		45.45	10,635															
				INT. FINISH	2	DRYWALL	1.00	D	AGR	N	ATT GARAGE	528		66.46	35,092															
				HEATING/COOLING	11	HT WATER CL AIR	1.05	E	BMF	N	BSMT FINISH	468		47.12	22,050															
				FUEL SOURCE	1	OIL	1.00	E	ATU	N	ATTIC UNF	234		45.45	10,635															
				USE	0		1.00	F21	O	FPL 2S 1OP	1		9,472.80	9,473																
								FIX	O	XTRA FIXTURES	5		2,290.06	11,450																
<table border="1"> <thead> <tr> <th>EFF.YR/AGE</th> <td colspan="2">2012 / 10</td> </tr> </thead> <tbody> <tr> <td>COND</td> <td>7</td> <td>7 %</td> </tr> <tr> <td>FUNC</td> <td>0</td> <td></td> </tr> <tr> <td>ECON</td> <td>0</td> <td></td> </tr> <tr> <td>DEPR</td> <td>7</td> <td>% GD 93</td> </tr> </tbody> </table>																EFF.YR/AGE	2012 / 10		COND	7	7 %	FUNC	0		ECON	0		DEPR	7	% GD 93
EFF.YR/AGE	2012 / 10																													
COND	7	7 %																												
FUNC	0																													
ECON	0																													
DEPR	7	% GD 93																												
<table border="1"> <tr> <td>RCNLD</td> <td colspan="2">\$445,800</td> </tr> </table>																RCNLD	\$445,800													
RCNLD	\$445,800																													