

Key: 1377

Town of Bourne - Fiscal Year 2024

12/18/2023 6:02 pm SEQ #: 1.381

LEGALS

CURRENT OWNER				PARCEL ID				LOCATION				
MANSFIELD TYLER P & JESSICA L PERRY 9 FLINTLOCK LANE SAGAMORE BEACH, MA 02562				7.2-19-0				9 FLINTLOCK LN				
				TRANSFER HISTORY				DOS	T	SALE PRICE	BK-PG (Cert)	
				MANSFIELD TYLER P & DONOVAN CHRISTOPHER M & MCKAY DANIEL C & NICOLE L				12/28/2017	QS	285,000	(215068)	
						05/01/2015	N	250,000	(206112)			
						04/22/2004	F	100	(172751)			

CLASS	CLASS%	DESCRIPTION			BN ID	BN	CARD	
1010	100	SINGLE FAMILY				1	1 of 1	
PMT NO	PMT DT	TY	DESC	AMOUNT	INSP	BY	1st	%
EXB-21-168	03/12/2021	15	INSULATE/WEA	1,809			100	100
07088	02/22/2007	2	ADDITIONS	9,000	06/27/2008	JH	100	100
960440	09/13/1996	3	ALT/RENO		08/27/1997	JC	100	100
910610	11/27/1991	10	WOODSTOVE	1,400	02/01/1992	HS	100	100

LAND

CD	T	AC/SF/UN	Nbhd	Infl1	N Index	ADJ BASE	SAF	Topo	Lpi	VC	CREDIT AMT	ADJ VALUE				
100	S	10,700	1	1.00	100	1.00	100	1.00	259,270	2.94	A	1.00	R04	1.10		187,460

DETACHED

TOTAL	10,716 SF	ZONING	1	FRNT	85	ASSESSED	CURRENT	PREVIOUS
Nbhd	N SAG	NOTE	LAND	187,500	165,900			
Infl1	AVG		BUILDING	324,600	287,300			
N_Index	AVG		DETACHED	0	0			
			OTHER	0	0			
TOTAL				512,100	453,200			

TY	QUAL	COND	DIM/NOTE	YB	UNITS	ADJ PRICE	RCNLD
SHF	A	1.00	50 0.50 8 X 8			0.00	

PHOTO 07/07/2020

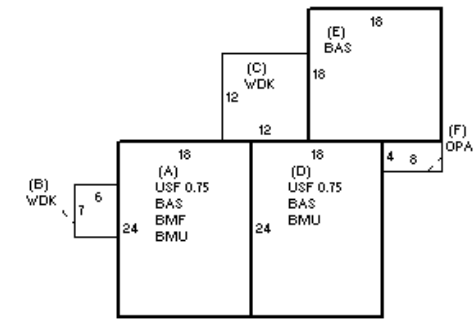

BUILDING

BUILDING	CD	ADJ	DESC	MEASURE	7/15/2021	NMP
MODEL	1		RESIDENTIAL	LIST	6/1/2016	EST
STYLE	4	1.05	CAPE [100%]	REVIEW		
QUALITY	A	1.00	AVERAGE [100%]			
FRAME	1	1.00	WOOD FRAME [100%]			

BLDG COMMENTS

G

YEAR BLT	1976	SIZE ADJ	1.010	ELEMENT	CD	DESCRIPTION	ADJ	S	BAT	T	DESCRIPTION	UNITS	YB	ADJ PRICE	RCN	TOTAL RCN	410,922	
NET AREA	1,836	DETAIL ADJ	1.000	FOUNDATION	4	FLR/WALL(FULL)	1.00	+	BMU	N	BSMT UNFINISHED	864		40.14	34,685	CONDITION ELEM	CD	
\$NLA(RCN)	\$224	OVERALL	1.090	EXT COVER	1	WOOD SHINGLE	1.02	A	BMF	N	BSMT FINISH	432		48.24	20,838	EXTERIOR	A	
				ROOF SHAPE	1	GABLE	1.00	+	BAS	L	BASE AREA	864	1976	211.34	182,594	INTERIOR	A	
				ROOF COVER	1	ASPH/COMP SHIN	1.00	+	USF	L	UPPER STORY FIN	648	1976	119.70	77,568	KITCHEN	A	
				FLOOR COVER	1	HARDWOOD	1.02	+	WDK	N	WOOD DECK	186		38.51	7,163	BATHS	A	
				INT. FINISH	2	DRYWALL	1.00	E	BAS	L	BASE AREA	324	2007	211.34	68,473	HEAT	A	
				HEATING/COOLING	1	FORCED AIR	1.00	F	OPA	N	OPEN PORCH	32		89.69	2,870	ELECT	A	
				FUEL SOURCE	2	GAS	1.00	F21	O	FPL 2S 1OP	1		9,697.80	9,698				
				USE	0		1.00	FIX	O	XTRA FIXTURES	3		2,344.57	7,034				
																	EFF.YR/AGE	1998 / 24
																	COND	21 21 %
																	FUNC	0
																	ECON	0
																	DEPR	21 % GD 79
																	RCNLD	\$324,600