

Key: 14784

Town of Bourne - Fiscal Year 2024

12/18/2023 6:02 pm SEQ #: 11.688

LEGAL

CURRENT OWNER		PARCEL ID	LOCATION			
TSAFFARAS PETER 2 SYCAMORE AVE SAGAMORE BEACH, MA 02562		3.0-242-0	2 SYCAMORE AVE			
TRANSFER HISTORY		DOS	T	SALE PRICE	BK-PG (Cert)	
TSAFFARAS PETER		07/16/2021	QS	740,000	34300-158	
PAINE ROBERT &		10/20/2000	QS	409,700	13309-86	
CIMENO J SCOTT TR		11/23/1999	G	425,000	12682-13	

CLASS	CLASS%	DESCRIPTION		BN ID	BN	CARD		
1010	100	SINGLE FAMILY			1	1 of 1		
PMT NO	PMT DT	TY	DESC	AMOUNT	INSP	BY	1st	%
EXB-21-617	09/07/2021	15	INSULATE/WEA	7,079				
200476	08/08/2000	1	NEW CONSTRUC	150,000	11/24/2000	TL	100	100

LAND

CD	T	AC/SF/UN	Nbhd	Infl1	N Index	ADJ BASE	SAF	Topo	Lpi	VC	CREDIT AMT	ADJ VALUE
100	S	40,000 1	1.00	100	1.00	259,270	1.00	A	1.00	R04	1.10	238,030
300	A	0.013 1	1.00	100	1.00	17,930	1.00	A	1.00	R04	1.10	230

TOTAL	40,554 SF	ZONING	1	FRNT	299	ASSESSED	CURRENT	PREVIOUS
Nbhd	N SAG	NOTE	LAND	238,300	210,900			
Infl1	AVG		BUILDING	616,200	551,900			
N_Index	AVG		DETACHED	0	0			
			OTHER	0	0			
			TOTAL	854,500	762,800			

DETACHED

TY	QUAL	COND	DIM/NOTE	YB	UNITS	ADJ PRICE	RCNLD	PHOTO	08/06/2021
									

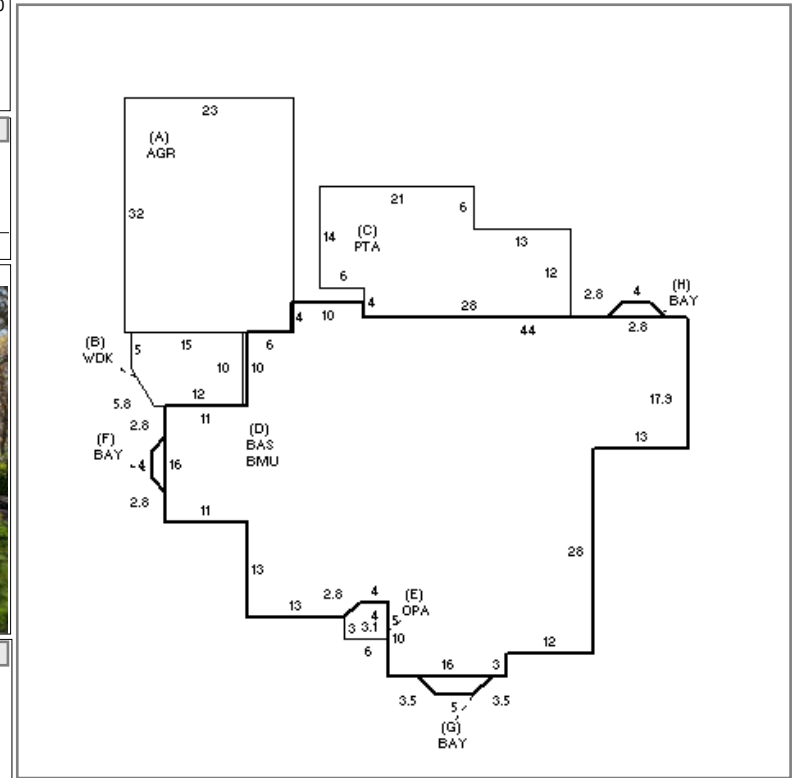

BUILDING

BUILDING	CD	ADJ	DESC	MEASURE	1/18/2022	NMP
MODEL	1		RESIDENTIAL	LIST	12/28/2017	TL
STYLE	8	1.10	CONTEMPORARY [100%]	REVIEW	8/6/2021	RP
QUALITY	G	1.10	GOOD [100%]			
FRAME	1	1.00	WOOD FRAME [100%]			

YEAR BLT	2000	SIZE ADJ	1.000	ELEMENT	CD	DESCRIPTION	ADJ	S	BAT	T	DESCRIPTION	UNITS	YB	ADJ PRICE	RCN
NET AREA	2,571	DETAIL ADJ	1.000	FOUNDATION	4	FLR/WALL(FULL)	1.00	A	AGR	N	ATT GARAGE	736		76.10	56,008
\$NLA(RCN)	\$289	OVERALL	1.190	EXT COVER	1	WOOD SHINGLE	1.02	B	WDK	N	WOOD DECK	143		51.73	7,397
				ROOF SHAPE	1	GABLE	1.00	C	PTA	N	PATIO	510		17.80	9,078
				ROOF COVER	1	ASPH/COMP SHIN	1.00	D	BMU	N	BSMT UNFINISHED	2,528		36.00	90,998
				FLOOR COVER	1	HARDWOOD	1.02	D	BAS	L	BASE AREA	2,528	2000	215.25	544,153
				INT. FINISH	2	DRYWALL	1.00	E	OPA	N	OPEN PORCH	28		106.64	2,986
				HEATING/COOLING	11	HT WATER CL AIR	1.05	+	BAY	L	BAYWINDOW	43	2000	237.05	10,193
				FUEL SOURCE	1	OIL	1.00	F	F11	O	FPL 1S 1OP	1		10,495.60	10,496
				USE	0		1.00		FIX	O	XTRA FIXTURES	4		2,787.53	11,150

TOTAL RCN	742,458
CONDITION ELEM	CD
EXTERIOR	A
INTERIOR	A
KITCHEN	A
BATHS	A
HEAT	A
ELECT	A
EFF.YR/AGE	2002 / 20
COND	17 17 %
FUNC	0
ECON	0
DEPR	17 % GD 83
RCNLD	\$616,200