

Key: 14820

Town of Bourne - Fiscal Year 2024

12/18/2023 6:02 pm SEQ #: 11.724

LEGAL

LAND

DETACHED

BUILDING

INDING

CURRENT OWNER				PARCEL ID				LOCATION			
NOONAN JOHN E III OF KRIJO REALTY TR PO BOX 699 CATAUMET, MA 02534-0748				52.0-82-0				12 MILLENNIUM DR			
TRANSFER HISTORY				DOS	T	SALE PRICE	BK-PG (Cert)				
NOONAN JOHN E III OF NOONAN JOHN E III				09/08/1999	G	12526-56	10317-136				
				07/26/1996		90,000					

CLASS	CLASS%	DESCRIPTION			BN ID	BN	CARD	
3160	100	OTHR STORAGE.WAREHSE			6	1	1 of 1	
PMT NO	PMT DT	TY	DESC	AMOUNT	INSP	BY	1st	%
01536	08/27/2001	2	ADDITIONS	32,000	02/20/2002	MJ	100	100
990602	09/27/1999	1	NEW CONSTRUC	217,000	12/08/2000	EB	100	100
15261		13	OTHER				100	100

CD	T	AC/SF/UN	Nbhd	Infl1	N Index	ADJ BASE	SAF	Topo	Lpi	VC	CREDIT AMT	ADJ VALUE				
103	S	20,000	C-6	1.00	100	1.00	100	1.00	546,600	1.48	A	1.00	65	1.20		372,050
203	A	0.634	C-6	1.00	100	1.00	100	1.00	191,400	1.00	A	1.00	65	1.20		121,350

TOTAL	1.093 Acres	ZONING	4	FRNT	0	ASSESSED	CURRENT	PREVIOUS
Nbhd	POCASS/CATAUMET	NOTE	LAND	493,400	474,500			
Infl1	AVG		BUILDING	487,300	432,500			
N_Index	AVG		DETACHED	23,600	21,700			
			OTHER	0	0			
		TOTAL		1,004,300	928,700			

TY	QUAL	COND	DIM/NOTE	YB	UNITS	ADJ PRICE	RCNLD	
SW1	G	1.20	10 0.90	5X10	2001	50	21.96	1,000
PAV	G	1.20	50 0.50		2001	30,000	1.44	21,600
C06	A	1.00	50 0.50			200	10.10	1,000



BUILDING	CD	ADJ	DESC	MEASURE	7/20/2021	RP
MODEL	5		CIM-5	LIST	7/20/2021	EST
STYLE	53	0.93	STORAGE GARAGE [70%]	REVIEW	7/20/2021	RP
QUALITY	G	1.10	GOOD [100%]			
FRAME	4	0.98	METAL [100%]			

YEAR BLT	2000	SIZE ADJ	1.000	ELEMENT	CD	DESCRIPTION	ADJ	S	BAT	T	DESCRIPTION	UNITS	YB	ADJ PRICE	RCN	TOTAL RCN	616.889
NET AREA	13,512	DETAIL ADJ	0.801	FOUNDATION	4	FLR & WALL	1.00	A	BAS	L	BASE AREA	3,762	2000	47.08	177,109	CONDITION ELEM	CD
\$NLA(RCN)	\$46	OVERALL	1.000	EXT. COVER	19	PREFAB METAL	1.00	A	USF	L	UP-STRY FIN	3,762	2000	39.92	150,189	EXTERIOR	A
				ROOF SHAPE	1	GABLE	1.00	+	WDK	N	WOOD DECK	188		26.95	5,067	INTERIOR	A
				ROOF COVER	10	METAL	1.00	G	BAS	L	BASE AREA	5,708	2000	47.08	268,724	CDN/APP	A
				FLOOR COVER	9	CONCRETE	0.95	+	BAS	L	BASE AREA	280	2000	47.08	13,182		
				INT. FINISH	6	MINIMUM	0.95	H	MZU	N	UNF MEZ	120		9.35	1,122		
				HEATING/COOL	15	SUSPENDED	0.95	I	MZU	N	UNF MEZ	160		9.35	1,496		
				FUEL SOURCE	2	GAS	1.00										
				NAF	0		1.00										

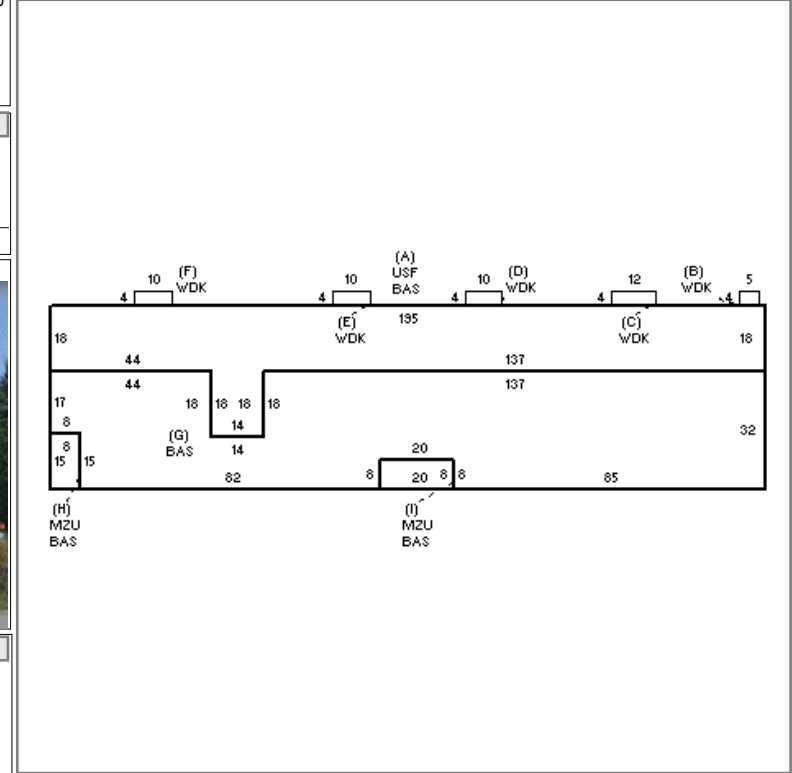

EFF.YR/AGE	2001 / 21
COND	21 21 %
FUNC	0
ECON	0
DEPR	21 % GD 79
RCNLD	\$487,300