

Key: 1515

Town of Bourne - Fiscal Year 2024

12/18/2023 6:02 pm SEQ #: 1.517

LEGAL

LAND

DETACHED

BUILDING

CURRENT OWNER				PARCEL ID				LOCATION			
LEAVITT JESSERIE KAREN 6 SACHEM DR SAGAMORE BEACH, MA 02562				7.3-92-0				6 SACHEM DR			
TRANSFER HISTORY				DOS	T	SALE PRICE	BK-PG (Cert)				
LEAVITT JESSERIE KAREN				04/08/2016	L	210,000	29565-232				
FEDERAL NTNL MORT ASSOC				04/03/2015	L	268,626	28779-193				
BISSONNETTE LAWRENCE MAR				04/03/2015	F		28779-187+89				

CLASS	CLASS%	DESCRIPTION			BN ID	BN	CARD	
1010	100	SINGLE FAMILY				1	1 of 1	
PMT NO	PMT DT	TY	DESC	AMOUNT	INSP	BY	1st	%
17350	05/11/2017	3	ALT/RENO	60,000	05/23/2018	TL	100	100
980480	08/17/1998	2	ADDITIONS	3,500	03/10/1999	JS	100	100
980378	07/01/1998	9	DECK	5,300	03/10/1999	JS	100	100
910129	04/12/1991	3	ALT/RENO	2,500	03/01/1992	HS	100	100

CD	T	AC/SF/UN	Nbhd	Infl1	N Index	ADJ BASE	SAF	Topo	Lpi	VC	CREDIT AMT	ADJ VALUE					
100	S	24,845	1	1.00	100	1.00	100	1.00	259,270	1.43	A	1.00	R04	1.10			211,860

TOTAL	24,829 SF	ZONING	1	FRNT	185	ASSESSED	CURRENT	PREVIOUS
Nbhd	N SAG	NOTE	LAND	211,900	187,500			
Infl1	AVG		BUILDING	376,500	333,200			
N_Index	AVG		DETACHED	0	0			
			OTHER	0	0			
		TOTAL		588,400	520,700			

TY	QUAL	COND	DIM/NOTE	YB	UNITS	ADJ PRICE	RCNLD



BLDG COMMENTS

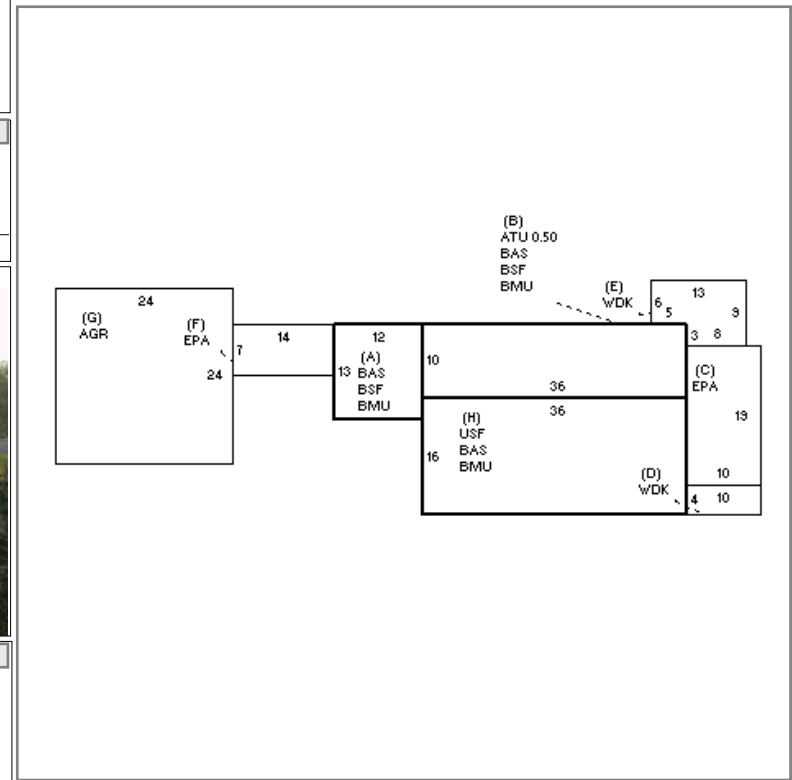

BUILDING	CD	ADJ	DESC	MEASURE	1/6/2022	NMP
MODEL	1		RESIDENTIAL	LIST	9/15/2015	TL
STYLE	4	1.05	CAPE [100%]	REVIEW	5/23/2018	TL
QUALITY	A	1.00	AVERAGE [100%]			
FRAME	1	1.00	WOOD FRAME [100%]			

YEAR BLT	1965	SIZE ADJ	1.010	ELEMENT	CD	DESCRIPTION	ADJ	S	BAT	T	DESCRIPTION	UNITS	YB	ADJ PRICE	RCN
NET AREA	1,668	DETAIL ADJ	1.000	FOUNDATION	4	FLR/WALL(FULL)	1.00	+	BMU	N	BSMT UNFINISHED	1,092		39.41	43,034
\$NLA(RCN)	\$262	OVERALL	1.070	EXT COVER	1	WOOD SHINGLE	1.02	+	BSF	N	BSMT SEMI-FIN	516		19.87	10,253
				ROOF SHAPE	1	GABLE	1.00	+	BAS	L	BASE AREA	1,092	1965	207.46	226,544
				ROOF COVER	1	ASPH/COMP SHIN	1.00	B	ATU	N	ATTIC UNF	180		45.68	8,222
				FLOOR COVER	1	HARDWOOD	1.02	+	EPA	N	ENCLOSED PORCH	288		70.50	20,303
				INT. FINISH	2	DRYWALL	1.00	+	WDK	N	WOOD DECK	142		42.70	6,064
				HEATING/COOLING	5	ELECTRIC BB	0.98	G	AGR	N	ATT GARAGE	576		66.79	38,473
				FUEL SOURCE	3	ELECTRIC	1.00	H	USF	L	UPPER STORY FIN	576	1965	118.91	68,494
				USE	0		1.00		F21	O	FPL 2S 1OP	1		9,519.90	9,520
									FIX	O	XTRA FIXTURES	3		2,301.53	6,905

TOTAL RCN	437,810
CONDITION ELEM	CD
EXTERIOR	A
INTERIOR	G
KITCHEN	G
BATHS	G
HEAT	A
ELECT	U
EFF.YR/AGE	2005 / 17
COND	14 14 %
FUNC	0
ECON	0
DEPR	14 % GD 86
RCNLD	\$376,500