

Key: 15268

Town of Bourne - Fiscal Year 2024

12/18/2023 6:02 pm SEQ #: 11.751

LEGAL

LAND

DETACHED

BUILDING

CURRENT OWNER				PARCEL ID				LOCATION			
THOMAS JOEL P ETUX KATIE A THOMAS 7 TIFFANY RD BOURNE, MA 02532				35.1-196-0				7 TIFFANY RD			
TRANSFER HISTORY				DOS	T	SALE PRICE	BK-PG (Certs)				
THOMAS JOEL P ETUX				08/23/2013	QS	413,300	27642-318				
DUCASSE GEORGE A IV ETUX				08/29/2003	QS	462,900	17553-77				
OLD CENTRE HOMES INC				08/01/2002	F	1	15430-184				

CLASS	CLASS%	DESCRIPTION			BN ID	BN	CARD	
1010	100	SINGLE FAMILY				1	1 of 1	
PMT NO	PMT DT	TY	DESC	AMOUNT	INSP	BY	1st	%
B-20-24	04/16/2020	14	SOLAR	41,472			100	100
15606	07/20/2015	8	POOL	17,000	04/04/2018		100	100
01725	11/20/2001	1	NEW CONSTRU	200,000	01/06/2003	TL	100	100

CD	T	AC/SF/UN	Nbhd	Infl1	N Index	ADJ BASE	SAF	Topo	Lpi	VC	CREDIT AMT	ADJ VALUE
100	S	40,000	9	1.00	100	247,485	1.00	A	1.00	R05	1.05	227,210
300	A	0.007	9	1.00	100	17,115	1.00	A	1.00	R05	1.05	120

TOTAL	40,293 SF	ZONING	FRNT	0	ASSESSED	CURRENT	PREVIOUS
Nbhd	MO BCH	NOTE	LAND	227,300	201,200		
Infl1	AVG		BUILDING	503,200	445,300		
N_Index	AVG		DETACHED	17,500	16,600		
			OTHER	0	0		
			TOTAL	748,000	663,100		

TY	QUAL	COND	DIM/NOTE	YB	UNITS	ADJ PRICE	RCNLD
IPG	G	1.20	10 0.90	16 X 34	2015	544	35.66
							17,500



BUILDING	CD	ADJ	DESC	MEASURE	4/16/2021	RP
MODEL	1		RESIDENTIAL	LIST	4/16/2021	EST
STYLE	5	1.00	COLONIAL [100%]	REVIEW	4/16/2021	RP
QUALITY	G	1.10	GOOD [100%]			
FRAME	1	1.00	WOOD FRAME [100%]			

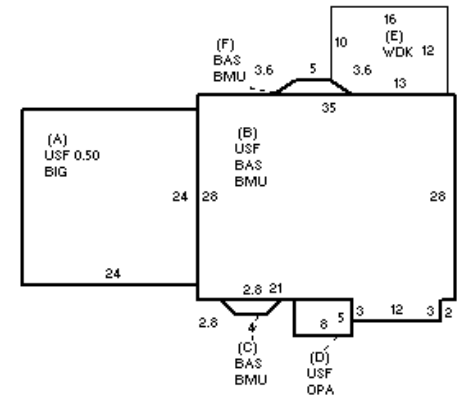

YEAR BLT	2002	SIZE ADJ	1.005	ELEMENT	CD	DESCRIPTION	ADJ	S	BAT	T	DESCRIPTION	UNITS	YB	ADJ PRICE	RCN	TOTAL RCN	565,434			
NET AREA	2,388	DETAIL ADJ	1.000	FOUNDATION	4	FLR/WALL(FULL)	1.00	A	BIG	N	BUILT-IN GARAGE	576		94.48	54,419	CONDITION ELEM	CD			
\$NLA(RCN)	\$237	OVERALL	1.090	EXT COVER	1	WOOD SHINGLE	1.02	+	USF	L	UPPER STORY FIN	1,344	2002	125.28	168,378	EXTERIOR	A			
				ROOF SHAPE	1	GABLE	1.00	+	BMU	N	BSMT UNFINISHED	1,044		43.94	45,873	INTERIOR	A			
				ROOF COVER	1	ASPH/COMP SHIN	1.00	+	BAS	L	BASE AREA	1,044	2002	231.32	241,497	KITCHEN	G			
				FLOOR COVER	1	HARDWOOD	1.02	D	OPA	N	OPEN PORCH	40		98.18	3,927	BATHS	G			
				INT. FINISH	2	DRYWALL	1.00	E	WDK	N	WOOD DECK	189		42.15	7,966	HEAT	A			
				HEATING/COOLING	11	HT WATER CL AIR	1.05	F21	O	FPL 2S 1OP	1		10,614.80	10,615	ELECT	A				
				FUEL SOURCE	1	OIL	1.00	FIX	O	XTRA FIXTURES	7		2,566.13	17,963						
				USE	0		1.00	JAC	O	JACUZZI	1		14,797.30	14,797						
																		EFF.YR/AGE	2008 / 14	
																		COND	11 11 %	
																		FUNC	0	
																		ECON	0	
																		DEPR	11 % GD 89	
																		RCNLD	\$503,200	