

Key: 1539

Town of Bourne - Fiscal Year 2024

12/18/2023 6:02 pm SEQ #: 1.541

LEGALS

CURRENT OWNER				PARCEL ID				LOCATION			
FERRIGNO DINA TRS DINA MARIE FERRIGNO TRUST 23 DIANDY ROAD SAGAMORE BEACH, MA 02562				7.3-114-0				23 DIANDY RD			
TRANSFER HISTORY				DOS	T	SALE PRICE	BK-PG (Cert)				
FERRIGNO DINA TRS DINA MA				01/14/2019	F	100	N/A-N/A				
FERRIGNO JOSEPH &				05/24/1993	F	100	8590-072				
FERRIGNO JOSEPH &				03/26/1990	QS	155,000	N/A-N/A				

CLASS	CLASS%	DESCRIPTION			BN ID	BN	CARD	
1010	100	SINGLE FAMILY				1	1 of 1	
PMT NO	PMT DT	TY	DESC	AMOUNT	INSP	BY	1st	%
B-22-388	02/03/2023	9	DECK	10,000	05/01/2023	SL	100	100
19290	04/17/2019	3	ALT/RENO	45,000	08/29/2019		100	100
10011	01/20/2010	10	WOODSTOVE	5,500	04/22/2010	TL	100	100
970227	05/16/1997	6	FENCE	4,500	04/21/1998	JS	100	100

LAND

CD	T	AC/SF/UN	Nbhd	Infl1	N Index	ADJ BASE	SAF	Topo	Lpi	VC	CREDIT AMT	ADJ VALUE					
100	S	25,000	1	1.00	100	1.00	100	1.00	259,270	1.43	A	1.00	R04	1.10			212,140

DETAILED

TOTAL	25,003 SF	ZONING	1	FRNT	126	ASSESSED	CURRENT	PREVIOUS
Nbhd	N SAG	NOTE	LAND	212,100	187,800			
Infl1	AVG		BUILDING	431,200	375,000			
N_Index	AVG		DETACHED	0	0			
			OTHER	0	0			
			TOTAL	643,300	562,800			

TY	QUAL	COND	DIM/NOTE	YB	UNITS	ADJ PRICE	RCNLD	PHOTO	05/01/2023
SHF	G	1.20	10 0.90	8X10		0.00			

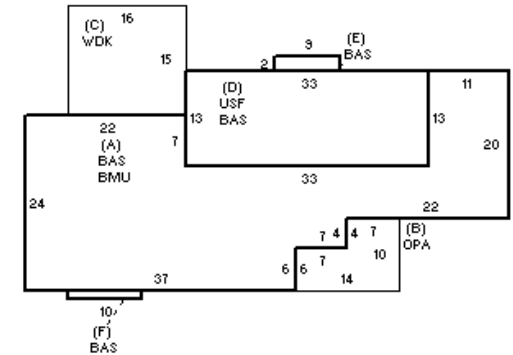

BUILDING

BUILDING	CD	ADJ	DESC	MEASURE	5/1/2023	SL
MODEL	1		RESIDENTIAL	LIST	8/29/2019	EST
STYLE	8	1.10	CONTEMPORARY [100%]	REVIEW	5/1/2023	SL
QUALITY	+	1.05	AVERAGE + [100%]			
FRAME	1	1.00	WOOD FRAME [100%]			

BLDG COMMENTS		

G

YEAR BLT	1984	SIZE ADJ	1.005	ELEMENT	CD	DESCRIPTION	ADJ	S	BAT	T	DESCRIPTION	UNITS	YB	ADJ PRICE	RCN	TOTAL RCN	513,322
NET AREA	2,043	DETAIL ADJ	1.000	FOUNDATION	4	FLR/WALL(FULL)	1.00	A	BMU	N	BSMT UNFINISHED	1,157		44.64	51,644	CONDITION ELEM	CD
\$NLA(RCN)	\$251	OVERALL	1.160	EXT COVER	1	WOOD SHINGLE	1.02	B	OPA	N	OPEN PORCH	112		83.99	9,407	EXTERIOR	A
				ROOF SHAPE	1	GABLE	1.00	C	WDK	N	WOOD DECK	240		31.70	7,609	INTERIOR	A
				ROOF COVER	1	ASPH/COMP SHIN	1.00	+	BAS	L	BASE AREA	1,614	1984	221.02	356,723	KITCHEN	G
				FLOOR COVER	1	HARDWOOD	1.02	D	USF	L	UPPER STORY FIN	429	1984	134.69	57,782	BATHS	A
				INT. FINISH	2	DRYWALL	1.00		BMG	O	BSMT GARAGE	2		8,725.30	17,451	HEAT	A
				HEATING/COOLING	2	HOT WATER	1.02		FIX	O	XTRA FIXTURES	3		2,606.90	7,821	ELECT	U
				FUEL SOURCE	1	OIL	1.00		MST	O	MAS/METAL STACK	1		4,885.30	4,885		
				USE	0		1.00										

EFF. YR/AGE	2003 / 19	
COND	16	16 %
FUNC	0	
ECON	0	
DEPR	16	% GD 84
RCNLD	\$431,200	