

Key: 15711

Town of Bourne - Fiscal Year 2024

12/18/2023 6:02 pm SEQ #: 11.804

LEGALS

CURRENT OWNER		PARCEL ID	LOCATION			
MARINELLA ROBERT J SR ET UX PEARL R MARINELLA 4 DOROTHY WAY BOURNE, MA 02532		27.0-180-0	4 DOROTHY WAY			
TRANSFER HISTORY		DOS	T	SALE PRICE	BK-PG (Cert)	
MARINELLA ROBERT J SR ET		06/28/2001	QS	125,000	13989-224	
BILODEAU MICHAEL K &		02/13/2001	G	410,000	13555-60	

CLASS	CLASS%	DESCRIPTION			BN ID	BN	CARD	
1010	100	SINGLE FAMILY				1	1 of 1	
PMT NO	PMT DT	TY	DESC	AMOUNT	INSP	BY	1st	%
01369	06/26/2001	1	NEW CONSTRUC	225,000	09/09/2003	TL	100	100

LAND

CD	T	AC/SF/UN	Nbhd	Infl1	N Index	ADJ BASE	SAF	Topo	Lpi	VC	CREDIT AMT	ADJ VALUE				
100	S	40,000	6	1.00	100	1.00	100	1.00	235,700	1.00	A	1.00	R05	1.00		216,390
300	A	0.009	6	1.00	100	1.00	100	1.00	16,300	1.00	A	1.00	R05	1.00		150

TOTAL	40,359 SF	ZONING	1	FRNT	0	ASSESSED	CURRENT	PREVIOUS
Nbhd	BOURNE	NOTE FORMERLY PART OF MAP 27 PCL 70	LAND	216,500	191,600			
Infl1	AVG		BUILDING	557,800	499,400			
N_Index	AVG		DETACHED	1,800	1,700			
			OTHER	0	0			
			TOTAL	776,100	692,700			

TY	QUAL	COND	DIM/NOTE	YB	UNITS	ADJ PRICE	RCNLD	
SHF	A	1.00	10 0.90	10 X 12		120	16.42	1,800



BLDG COMMENTS

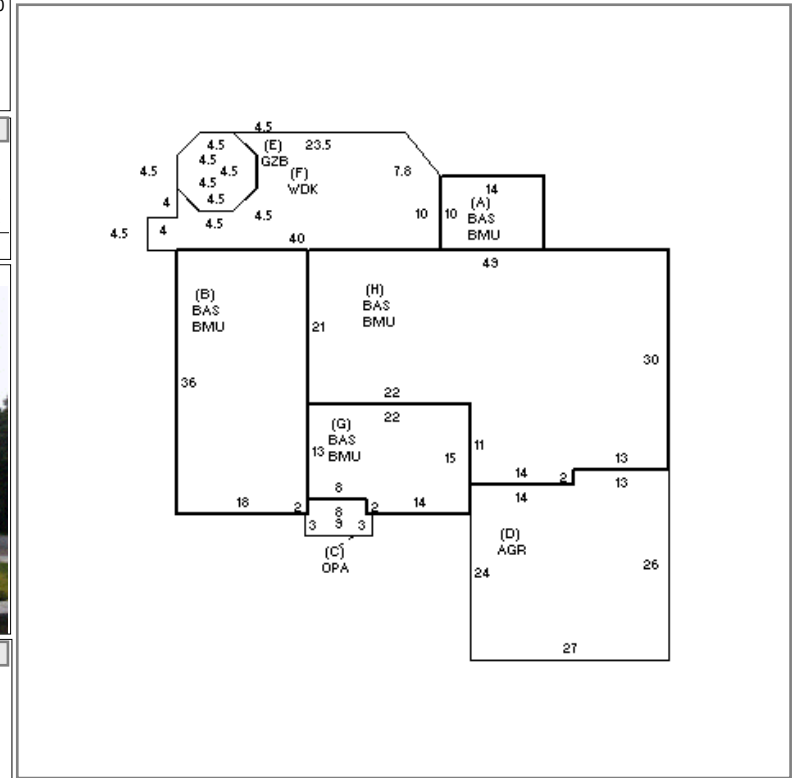

DETACHED

BUILDING	CD	ADJ	DESC	MEASURE	1/27/2017	TL
MODEL	1		RESIDENTIAL	LIST	1/27/2017	TL
STYLE	8	1.10	CONTEMPORARY [100%]	REVIEW		
QUALITY	A	1.00	AVERAGE [100%]			
FRAME	1	1.00	WOOD FRAME [100%]			

BUILDING

YEAR BLT	2001	SIZE ADJ	1.005	ELEMENT	CD	DESCRIPTION	ADJ	S	BAT	T	DESCRIPTION	UNITS	YB	ADJ PRICE	RCN	TOTAL RCN	648,595	
NET AREA	2,402	DETAIL ADJ	1.000	FOUNDATION	4	FLR/WALL(FULL)	1.00	+	BMU	N	BSMT UNFINISHED	2,402		32.33	77,667			
\$NLA(RCN)	\$270	OVERALL	1.170	EXT COVER	4	VINYL	1.00	+	BAS	L	BASE AREA	2,402	2001	193.36	464,440			
				ROOF SHAPE	2	HIP	1.02	C	OPA	N	OPEN PORCH	43		95.82	4,120	EXTERIOR	A	
				ROOF COVER	1	ASPH/COMP SHIN	1.00	D	AGR	N	ATT GARAGE	674		68.36	46,073	INTERIOR	G	
				FLOOR COVER	1	HARDWOOD	1.02	E	GZB	N	GAZEBO	98		85.01	8,331	KITCHEN	A	
				INT. FINISH	2	DRYWALL	1.00	F	WDK	N	WOOD DECK	480		25.12	12,056	BATHS	A	
				HEATING/COOLING	9	WARM-COOL AIR	1.03		PTA	N	PATIO	384		15.99	6,139	HEAT	A	
				FUEL SOURCE	2	GAS	1.00		FIX	O	XTRA FIXTURES	6		2,504.17	15,025	ELECT	A	
				USE	0		1.00		GFP	O	GAS FIREPLACE	1		7,525.40	7,525			
									WPL	O	WHIRLPOOL	1		7,218.50	7,219			
																EFF.YR/AGE	2005 / 17	
																COND	14	14 %
																FUNC	0	
																ECON	0	
																DEPR	14	% GD 86
																RCNLD	\$557,800	