

Key: 1599

Town of Bourne - Fiscal Year 2024

12/18/2023 6:02 pm SEQ #: 1.598

LEGAL

CURRENT OWNER				PARCEL ID				LOCATION			
HOWARD BARBARA J 16 SIASCONSET DR SAGAMORE BEACH, MA 02562-2724				7.4-48-0				16 SIASCONSET DR			
TRANSFER HISTORY				DOS	T	SALE PRICE	BK-PG (Cert)				
HOWARD BARBARA J				05/18/1988	O	50,000	(114260)				

CLASS	CLASS%	DESCRIPTION			BN ID	BN	CARD	
1010	100	SINGLE FAMILY				1	1 of 1	
PMT NO	PMT DT	TY	DESC	AMOUNT	INSP	BY	1st	%
05204	04/05/2005	9	DECK		09/19/2006	DB	100	100
2401	11/21/1988	1	NEW CONSTRUC	80,000	03/01/1992	HS	100	100

LAND

CD	T	AC/SF/UN	Nbhd	Infl1	N Index	ADJ BASE	SAF	Topo	Lpi	VC	CREDIT AMT	ADJ VALUE						
100	S	14,200	1	1.00	100	1.00	100	1.00	259,270	2.29	A	1.00	R04	1.10				193,500

TOTAL	14,201 SF	ZONING	1	FRNT	100	ASSESSED	CURRENT	PREVIOUS
Nbhd	N SAG	NOTE	LAND	193,500	171,300			
Infl1	AVG		BUILDING	387,800	347,500			
N_Index	AVG		DETACHED	1,200	1,100			
			OTHER	0	0			
			TOTAL	582,500	519,900			

DETACHED

TY	QUAL	COND	DIM/NOTE	YB	UNITS	ADJ PRICE	RCNLD
SHF	G	1.20	10 0.90 8 X 8		64	20.28	1,200

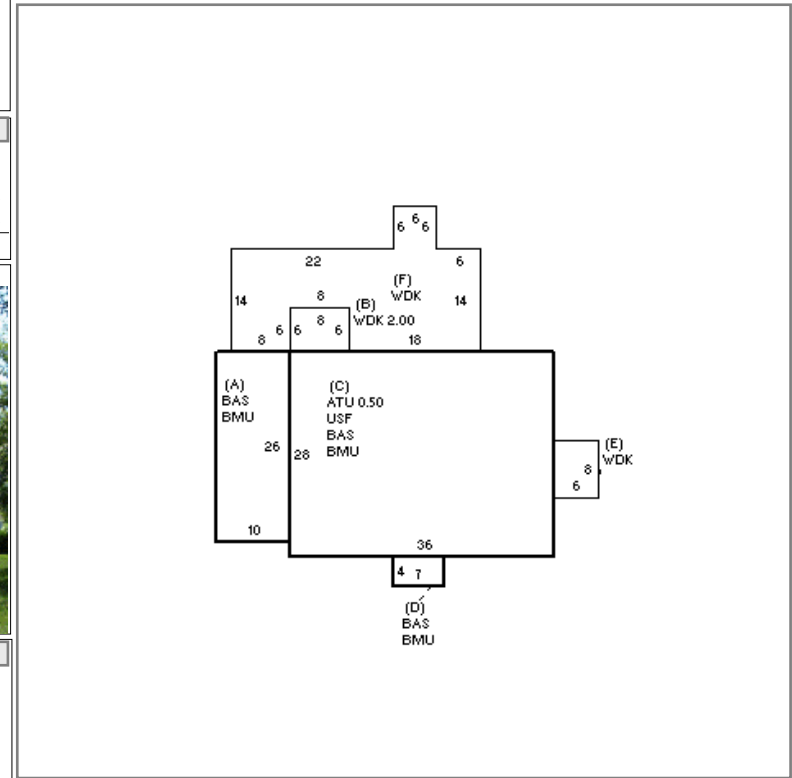

BUILDING

BUILDING	CD	ADJ	DESC	MEASURE	1/12/2022	NMP
MODEL	1		RESIDENTIAL	LIST	6/25/2008	EST
STYLE	5	1.00	COLONIAL [100%]	REVIEW	7/21/2008	ER
QUALITY	+	1.05	AVERAGE + [100%]			
FRAME	1	1.00	WOOD FRAME [100%]			

BLDG COMMENTS

G

YEAR BLT	1988	SIZE ADJ	1.005	ELEMENT	CD	DESCRIPTION	ADJ	S	BAT	T	DESCRIPTION	UNITS	YB	ADJ PRICE	RCN	TOTAL RCN	497,162		
NET AREA	2,304	DETAIL ADJ	1.000	FOUNDATION	4	FLR/WALL(FULL)	1.00	+	BMU	N	BSMT UNFINISHED	1,296		35.06	45,438	CONDITION ELEM	CD		
\$NLA(RCN)	\$216	OVERALL	1.040	EXT COVER	4	VINYL	1.00	+	BAS	L	BASE AREA	1,296	1988	206.30	267,368	EXTERIOR	A		
				ROOF SHAPE	1	GABLE	1.00	+	WDK	N	WOOD DECK	608		23.44	14,253	INTERIOR	A		
				ROOF COVER	1	ASPH/COMP SHIN	1.00	C	USF	L	UPPER STORY FIN	1,008	1988	114.10	115,014	KITCHEN	A		
				FLOOR COVER	1	HARDWOOD	1.02	C	ATU	N	ATTIC UNF	504		46.39	23,378	BATHS	A		
				INT. FINISH	2	DRYWALL	1.00		BMG	O	BSMT GARAGE	2		7,822.70	15,645	HEAT	A		
				HEATING/COOLING	2	HOT WATER	1.02		FIX	O	XTRA FIXTURES	5		2,337.16	11,686	ELECT	A		
				FUEL SOURCE	1	OIL	1.00		MST	O	MAS/METAL STACK	1		4,380.00	4,380				
				USE	0		1.00												
																		EFF.YR/AGE	1997 / 25
																		COND	22 22 %
																		FUNC	0
																		ECON	0
																		DEPR	22 % GD 78
																		RCNLD	\$387,800