

Key: 1616

Town of Bourne - Fiscal Year 2024

12/18/2023 6:02 pm SEQ #: 1.615

LEG  
A  
L

CURRENT OWNER				PARCEL ID				LOCATION			
GLYNN ROBERT J & CATHLEEN 52 GOVERNOR LONG ROAD HINGHAM, MA 02043				7.4-63-1				53 SACHEM DR			
TRANSFER HISTORY				DOS	T	SALE PRICE	BK-PG (Cert)				
GLYNN ROBERT J & CATHLEEN				12/27/2019	QS	319,000	32583-35				
HAYES HETTY				06/08/2017	F	1	30543-249				
HAYES HETTY				03/06/2014	F	1	28020-241				

CLASS	CLASS%	DESCRIPTION			BN ID	BN	CARD	
1010	100	SINGLE FAMILY				1	1 of 1	
PMT NO	PMT DT	TY	DESC	AMOUNT	INSP	BY	1st	%
EXB-23-711	10/27/2023	15	INSULATE/WEA	5,370			100	100
	06/02/2022	3	ALT/RENO		06/02/2022	SL	100	100
EXB-21-875	11/29/2021	3	ALT/RENO	8,500	06/02/2022	SL	100	100
B-20-72	05/18/2020	2	ADDITIONS	5,149	06/02/2022	SL	100	100
13555	08/20/2013	3	ALT/RENO	10,000			100	100

L  
A  
N  
D

CD	T	AC/SF/UN	Nbhd	Infl1	N Index	ADJ BASE	SAF	Topo	Lpi	VC	CREDIT AMT	ADJ VALUE				
100	S	14,230	1	1.00	100	1.00	100	1.00	259,270	2.29	A	1.00	R04	1.10		193,550

D  
E  
T  
A  
C  
H  
E  
D

TOTAL	14,244 SF	ZONING	1	FRNT	110	ASSESSED	CURRENT	PREVIOUS
Nbhd	N SAG	N O T E	LAND	193,600	171,300			
Infl1	AVG		BUILDING	284,100	251,400			
N_Index	AVG		DETACHED	0	0			
			OTHER	0	0			
			<b>TOTAL</b>	<b>477,700</b>	<b>422,700</b>			

TY	QUAL	COND	DIM/NOTE	YB	UNITS	ADJ PRICE	RCNLD	PHOTO
SHF	A	1.00	10 0.90 8 X 8			0.00		06/02/2022

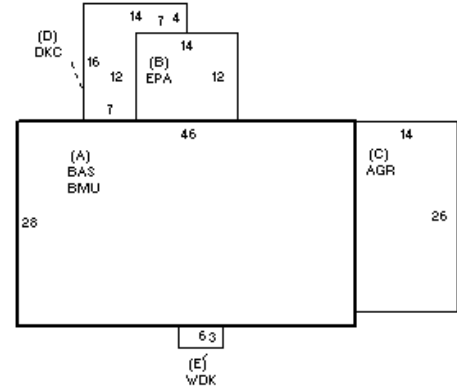

BLDG COMMENTS

B  
U  
I  
L  
D  
I  
N  
G

BUILDING	CD	ADJ	DESC	MEASURE	6/2/2022	SL
MODEL	1		RESIDENTIAL	LIST	6/2/2022	EST
STYLE	1	0.95	RANCH [100%]	REVIEW	6/2/2022	SL
QUALITY	A	1.00	AVERAGE [100%]			
FRAME	1	1.00	WOOD FRAME [100%]			

YEAR BLT	1975	SIZE ADJ	1.015	ELEMENT	CD	DESCRIPTION	ADJ	S	BAT	T	DESCRIPTION	UNITS	YB	ADJ PRICE	RCN	TOTAL RCN	350,723
NET AREA	1,288	DETAIL ADJ	1.000	FOUNDATION	4	FLR/WALL(FULL)	1.00	A	BMU	N	BSMT UNFINISHED	1,288		32.43	41,764	CONDITION ELEM	CD
\$NLA(RCN)	\$272	OVERALL	1.000	EXT COVER	1	WOOD SHINGLE	1.02	A	BAS	L	BASE AREA	1,288	1975	190.80	245,753	EXTERIOR	A
				ROOF SHAPE	1	GABLE	1.00	B	EPA	N	ENCLOSED PORCH	168		74.90	12,583	INTERIOR	A
				ROOF COVER	1	ASPH/COMP SHIN	1.00	C	AGR	N	ATT GARAGE	364		70.84	25,787	KITCHEN	A
				FLOOR COVER	3	W/W CARPET	1.00	D	DKC	N	DECK-COMPOSITE	140		63.73	8,922	BATHS	A
				INT. FINISH	2	DRYWALL	1.00	E	WDK	N	WOOD DECK	18		71.73	1,291	HEAT	U
				HEATING/COOLING	9	WARM-COOL AIR	1.03	F11	O	FPL 1S IOP	1		8,138.30	8,138	ELECT	A	
				FUEL SOURCE	1	OIL	1.00	FIX	O	XTRA FIXTURES	3		2,161.60	6,485			
				USE	0		1.00										

EFF.YR/AGE	2000 / 22
COND	19 19 %
FUNC	0
ECON	0
DEPR	19 % GD 81
RCNLD	\$284,100