

Key: 16444

Town of Bourne - Fiscal Year 2024

12/18/2023 6:02 pm SEQ #: 12.129

LEG
AL
LAND

CURRENT OWNER				PARCEL ID				LOCATION				
LINDE JAMES P 22 JILLIAN DR BOURNE, MA 02532				11.0-185-0				22 JILLIAN DR				
TRANSFER HISTORY				DOS	T	SALE PRICE	BK-PG (Cert)					
LINDE JAMES P				12/27/2021	F	100	(228710)					
CHURCHILL PAUL & JAMES LI				08/19/2019	F	100	(220298)					
WILLIAMS MARI ELLEN TRS				10/11/2017	QS	505,000	(214318)					
CD	T	AC/SF/UN	Nbhd	Infl1	N Index	ADJ BASE	SAF	Topo	Lpi	VC	CREDIT AMT	ADJ VALUE
100	S	40,000	2	1.00	100	212,130	1.00	A	1.00	R04	0.90	194,750
300	A	0.112	2	1.00	100	14,670	1.00	A	1.00	R04	0.90	1,640

CLASS	CLASS%	DESCRIPTION		BN ID	BN	CARD	
1010	100	SINGLE FAMILY			1	1 of 1	
PMT NO	PMT DT	TY	DESC	AMOUNT	INSP	BY	1st %
B-22-189	07/19/2022	3	ALT/RENO	58,000	01/09/2023	SL	100 100
06741	11/24/2006	3	ALT/RENO		01/09/2023	TL	100 100
04569	07/26/2004	1	NEW CONSTRUC	230,000	08/29/2022	TL	100 100
		3	ALT/RENO		09/18/2007	TL	100 100
		1	NEW CONSTRUC		09/18/2007	TL	100 100

DET
ACHED

TOTAL	1.030 Acres	ZONING	1	FRNT	103	ASSESSED	CURRENT	PREVIOUS
Nbhd	S SAG	NOTE OUT OF MAP 11 PARCEL 38; panoramic view of canal	LAND	196,400	173,800			
Infl1	AVG		BUILDING	656,400	556,400			
N_Index	AVG		DETACHED	26,000	0			
			OTHER	0	0			
			TOTAL	878,800	730,200			

TY	QUAL	COND	DIM/NOTE	YB	UNITS	ADJ PRICE	RCNLD
IPG	V	1.30	10 0.90	16 X 40	2022	640	33.92 19,500
PTD	V	1.30	10 0.90	34 X 65	2022	1,570	4.58 6,500

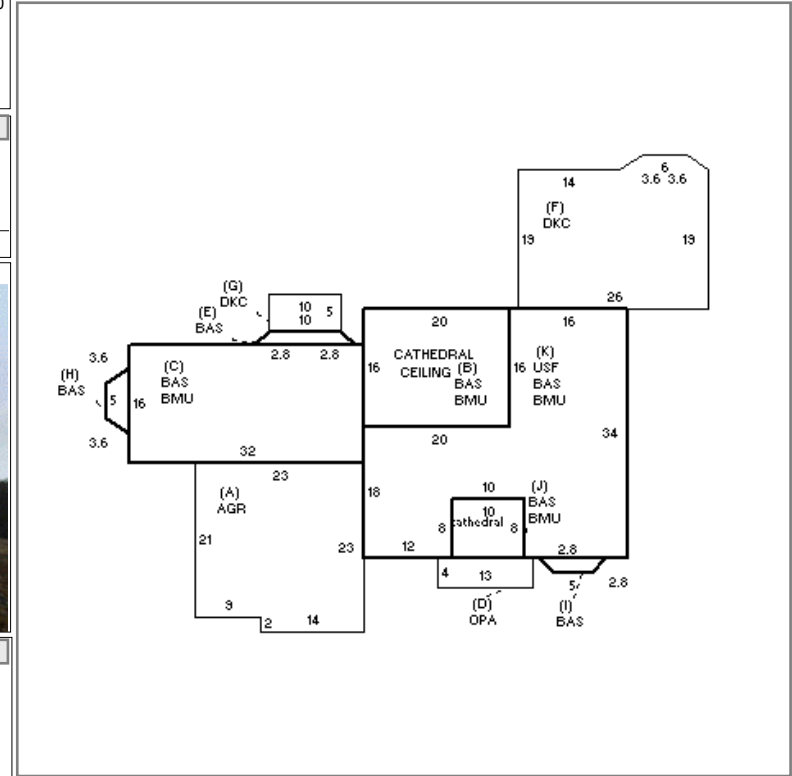

B
U
I
L
D
I
N
G

BUILDING	CD	ADJ	DESC	MEASURE	1/9/2023	SL
MODEL	1		RESIDENTIAL	LIST	1/9/2023	EST
STYLE	8	1.10	CONTEMPORARY [100%]	REVIEW	1/9/2023	SL
QUALITY	G	1.10	GOOD [100%]			
FRAME	1	1.00	WOOD FRAME [100%]			

BLDG COMMENTS

YEAR BLT	2006	SIZE ADJ	1.000	ELEMENT	CD	DESCRIPTION	ADJ	S	BAT	T	DESCRIPTION	UNITS	YB	ADJ PRICE	RCN	TOTAL RCN	745,912			
NET AREA	2,619	DETAIL ADJ	1.000	FOUNDATION	4	FLR/WALL(FULL)	1.00	A	AGR	N	ATT GARAGE	511		82.26	42,036	CONDITION ELEM	CD			
\$NLA(RCN)	\$285	OVERALL	1.210	EXT COVER	1	WOOD SHINGLE	1.02	+	BMU	N	BSMT UNFINISHED	1,736		39.47	68,515	EXTERIOR	A			
				ROOF SHAPE	2	HIP	1.02	D	OPA	N	OPEN PORCH	52		102.00	5,304	INTERIOR	A			
				ROOF COVER	1	ASPH/COMP SHIN	1.00	+	BAS	L	BASE AREA	1,795	2006	235.74	423,156	KITCHEN	A			
				FLOOR COVER	1	HARDWOOD	1.02	+	DKC	N	DECK-COMPOSITE	562		83.57	46,967	BATHS	A			
				INT. FINISH	1	PLASTER	1.00	K	USF	L	UPPER STORY FIN	824	2006	143.28	118,065	HEAT	A			
				HEATING/COOLING	11	HT WATER CL AIR	1.05	FIX	O	XTRA FIXTURES	6			2,834.58	17,008	ELECT	A			
				FUEL SOURCE	2	GAS	1.00	GFP	O	GAS FIREPLACE	1			8,518.40	8,518					
				USE	0		1.00	JAC	O	JACUZZI	1			16,344.70	16,345					
																		EFF.YR/AGE	2007 / 15	
																		COND	12 12 %	
																		FUNC	0	
																		ECON	0	
																		DEPR	12 % GD 88	
																		RCNLD	\$656,400	