

Key: 16455

Town of Bourne - Fiscal Year 2024

12/18/2023 6:02 pm SEQ #: 12.139

LEGAL

LAND

DETACHED

BUILDING

CURRENT OWNER				PARCEL ID				LOCATION					
DRAPER GEOFFREY C & HARRIET DRAPER				27.0-189-0				5 ZOLI LN					
5 ZOLI LANE				Bourne, MA 02532				TRANSFER HISTORY		DOS	T	SALE PRICE	BK-PG (Cert)
				DRAPER GEOFFREY C & HOLCOMB ALBERT J &				11/09/2017	QS	645,000	30887-341		
								10/15/1997	XX		11006-160		

CLASS	CLASS%	DESCRIPTION			BN ID	BN	CARD	
1010	100	SINGLE FAMILY				1	1 of 1	
PMT NO	PMT DT	TY	DESC	AMOUNT	INSP	BY	1st	%
B-22-38	02/02/2022	3	ALT/RENO	37,285	05/06/2022	TL	100	100
		3	ALT/RENO		10/15/2020	TL	100	100
19050	01/28/2019	15	INSULATE/WEA	3,187			100	100
18628	08/01/2018	14	SOLAR	32,987			100	100
08082	03/06/2008	1	NEW CONSTRUC	85,000	09/24/2009	TL	100	100

CD	T	AC/SF/UN	Nbhd	Infl1	N Index	ADJ BASE	SAF	Topo	Lpi	VC	CREDIT AMT	ADJ VALUE				
100	S	40,000	6	1.00	100	1.00	100	1.00	235,700	1.00	A	1.00	R05	1.00		216,390
300	A	1,444	6	1.00	100	1.00	100	1.00	16,300	1.00	A	1.00	R05	1.00		23,540

TOTAL	2.362 Acres	ZONING	1	FRNT	0	ASSESSED	CURRENT	PREVIOUS
Nbhd	BOURNE	NOTE OUT OF MAP 27 PARCEL 11	LAND	239,900	212,300			
Infl1	AVG		BUILDING	809,600	724,600			
N_Index	AVG		DETACHED	2,100	2,000			
			OTHER	0	0			
			TOTAL	1,051,600	938,900			

TY	QUAL	COND	DIM/NOTE	YB	UNITS	ADJ PRICE	RCNLD	
SHF	G	1.20	10 0.90	10 X 12	2004	120	19.71	2,100



BLDG COMMENTS

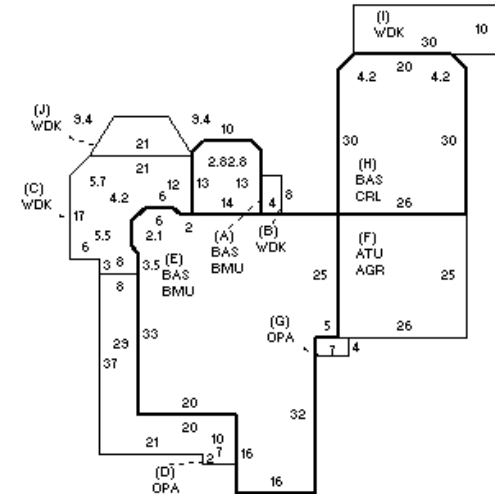

BUILDING	CD	ADJ	DESC	MEASURE	7/17/2017	DB
MODEL	1		RESIDENTIAL	LIST	5/6/2022	EST
STYLE	8	1.10	CONTEMPORARY [100%]	REVIEW	5/6/2022	TL
QUALITY	+	1.05	AVERAGE + [100%]			
FRAME	1	1.00	WOOD FRAME [100%]			

YEAR BLT	2003	SIZE ADJ	0.995	ELEMENT	CD	DESCRIPTION	ADJ	S	BAT	T	DESCRIPTION	UNITS	YB	ADJ PRICE	RCN	TOTAL RCN	920,043	
NET AREA	3,159	DETAIL ADJ	1.000	FOUNDATION	4	FLR/WALL(FULL)	1.00	+	BMU	N	BSMT UNFINISHED	2,085		34.22	71,355	CONDITION ELEM	CD	
\$NLA(RCN)	\$291	OVERALL	1.140	EXT COVER	4	VINYL	1.00	+	BAS	L	BASE AREA	2,085	2003	195.85	408,345	EXTERIOR	A	
				ROOF SHAPE	1	GABLE	1.00	+	WDK	N	WOOD DECK	880		25.44	22,388	INTERIOR	A	
				ROOF COVER	1	ASPH/COMP SHIN	1.00	+	OPA	N	OPEN PORCH	498		70.09	34,906	KITCHEN	A	
				FLOOR COVER	1	HARDWOOD	1.02	F	AGR	N	ATT GARAGE	650		69.24	45,005	BATHS	G	
				INT. FINISH	2	DRYWALL	1.00	F	ATU	N	ATTIC UNF	650		49.74	32,334	HEAT	A	
				HEATING/COOLING	2	HOT WATER	1.02	H	CRL	N	BSMT CRAWL	849		24.24	20,577	ELECT	A	
				FUEL SOURCE	1	OIL	1.00	H	BAS	L	BASE AREA	849	2008	195.85	166,276			
				USE	0		1.00	USF	L	UPPER STORY FIN	225	2003	131.05	29,486				
								BGF	N	BSMT GOOD FINIS	600		67.09	40,256				
								FIX	O	XTRA FIXTURES	14		2,536.35	35,509				
								GFP	O	GAS FIREPLACE	1		7,622.50	7,623				
								KIT	O	EXTRA KITCHEN	1		5,982.50	5,983				
																EFF.YR/AGE	2007 / 15	
																COND	12	12 %
																FUNC	0	
																ECON	0	
																DEPR	12	% GD 88
																RCNLD	\$809,600	