

Key: 16894

Town of Bourne - Fiscal Year 2024

12/18/2023 6:02 pm SEQ #: 12.224

LEGAL

LAND

DETACHED

BUILDING

CURRENT OWNER				PARCEL ID				LOCATION			
PROPHETT ROBERT E ETUX CATHLEEN C PROPHETT PO BOX 3123 POCASSET, MA 02559				48.0-92-0				57 LONG HILL RD			
TRANSFER HISTORY				DOS	T	SALE PRICE	BK-PG (Cert)				
PROPHETT ROBERT E ETUX				03/07/2016	L	366,500	29494-228				
FEDERAL NATIONAL MORT ASS				04/29/2014	L	427,541	28112-309				
FERNANDES RODNEY W &				03/31/2000	H	105,000	12921-230				

CLASS	CLASS%	DESCRIPTION			BN ID	BN	CARD	
1010	100	SINGLE FAMILY				1	1 of 1	
PMT NO	PMT DT	TY	DESC	AMOUNT	INSP	BY	1st	%
EXB-23-285	05/12/2023	14	SOLAR	31,725			100	100
H716	08/13/2020	8	POOL		04/27/2022		100	100
19941	10/10/2019	8	POOL	6,000			100	100
04719	09/22/2004	1	NEW CONSTRUCT	240,000	10/16/2006	TL	100	100

CD	T	AC/SF/UN	Nbhd	Inf1	N Index	ADJ BASE	SAF	Topo	Lpi	VC	CREDIT AMT	ADJ VALUE		
100	S	40,000	14	1.00	100	1.00	100	1.00	235,700	1.00	A	1.00 R04	1.00	216,390
300	A	0.142	14	1.00	100	1.00	100	1.00	16,300	1.00	A	1.00 R04	1.00	2,310

TOTAL	1.060 Acres		ZONING	1	FRNT	0	ASSESSED	CURRENT	PREVIOUS
Nbhd	CATAUMET		NOTE	LAND			218,700	193,600	
Inf1	AVG			BUILDING			548,800	491,000	
N_Index	AVG			DETACHED			16,400	15,600	
				OTHER			0	0	
				TOTAL			783,900	700,200	

TY	QUAL	COND	DIM/NOTE	YB	UNITS	ADJ PRICE	RCNLD	
IPG	G	1.20	10 0.90	16 X 32	2020	512	35.66	16,400

PHOTO 04/27/2022

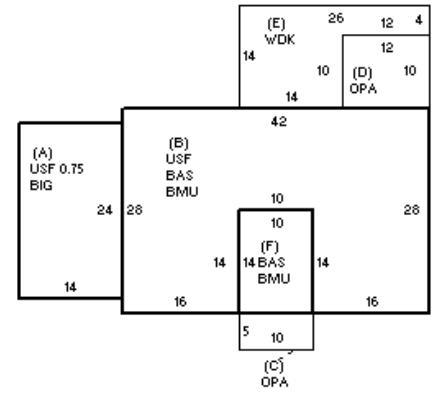

BUILDING	CD	ADJ	DESC	MEASURE	12/17/2019	TL
MODEL	1		RESIDENTIAL	LIST	12/17/2019	EST
STYLE	5	1.00	COLONIAL [100%]	REVIEW	4/27/2022	TL
QUALITY	G	1.10	GOOD [100%]			
FRAME	1	1.00	WOOD FRAME [100%]			

YEAR BLT	2004	SIZE ADJ	1.005
NET AREA	2,464	DETAIL ADJ	1.000
\$NLA(RCN)	\$247	OVERALL	1.060

ELEMENT	CD	DESCRIPTION	ADJ	S	BAT	T	DESCRIPTION	UNITS	YB	ADJ PRICE	RCN
FOUNDATION	4	FLR/WALL(FULL)	1.00	A	BIG	N	BUILT-IN GARAGE	336		103.76	34,862
EXT COVER	1	WOOD SHINGLE	1.02	+	USF	L	UPPER STORY FIN	1,288	2004	121.83	156,921
ROOF SHAPE	1	GABLE	1.00	+	BMU	N	BSMT UNFINISHED	1,176		42.73	50,252
ROOF COVER	1	ASPH/COMP SHIN	1.00	+	BAS	L	BASE AREA	1,176	2004	224.95	264,543
FLOOR COVER	1	HARDWOOD	1.02	+	OPA	N	OPEN PORCH	170		76.59	13,020
INT. FINISH	2	DRYWALL	1.00	E	WDK	N	WOOD DECK	244		30.35	7,405
HEATING/COOLING	2	HOT WATER	1.02		BMF	N	BSMT FINISH	1,176		40.67	47,832
FUEL SOURCE	2	GAS	1.00		FIX	O	XTRA FIXTURES	11		2,495.57	27,451
USE	0		1.00		GFP	O	GAS FIREPLACE	1		7,499.70	7,500

TOTAL RCN	609,785	
CONDITION ELEM	CD	
EXTERIOR	A	
INTERIOR	A	
KITCHEN	G	
BATHS	G	
HEAT	A	
ELECT	A	
EFF.YR/AGE	2009 / 13	
COND	10	10 %
FUNC	0	
ECON	0	
DEPR	10	% GD 90
RCNLD	\$548,800	