

Key: 1732

Town of Bourne - Fiscal Year 2024

12/18/2023 6:02 pm SEQ #: 1.746

LEGALS

CURRENT OWNER				PARCEL ID				LOCATION			
ANDERSON RICHARD K JR & BRIDGETTE E ANDERSON 14 GLACIER WAY BOURNE, MA 02532-2262				10.0-64-0				14 GLACIER WAY			
TRANSFER HISTORY				DOS	T	SALE PRICE	BK-PG (Cert)				
ANDERSON RICHARD K JR & FANTONI MARK A & PETER P				02/16/2001	N	287,040	13568-295				
				09/11/1998	G	217,000	11693-57				

CLASS	CLASS%	DESCRIPTION			BN ID	BN	CARD	
1010	100	SINGLE FAMILY				1	1 of 1	
PMT NO	PMT DT	TY	DESC	AMOUNT	INSP	BY	1st	%
06470	08/01/2006	13	OTHER		12/17/2015	TL	100	100
200483	08/08/2000	2	ADDITIONS	22,000	06/30/2007	DB	100	100
		1	NEW CONSTRUC	175,000	03/28/2001	TL	100	100

LAND

CD	T	AC/SF/UN	Nbhd	Infl1	N Index	ADJ BASE	SAF	Topo	Lpi	VC	CREDIT AMT	ADJ VALUE
100	S	40,249 3		1.00	100 1.00	188,560	1.00	A	1.00	R03 0.80		173,430

TOTAL	40,249 SF	ZONING	2	FRNT	130	ASSESSED	CURRENT	PREVIOUS
Nbhd	BDALE	NOTE	LAND	173,400	153,500			
Infl1	AVG		BUILDING	497,100	445,200			
N_Index	AVG		DETACHED	0	0			
			OTHER	0	0			
			TOTAL	670,500	598,700			

DETACHED

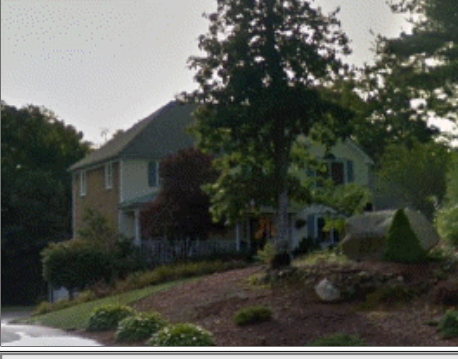
TY	QUAL	COND	DIM/NOTE	YB	UNITS	ADJ PRICE	RCNLD	PHOTO
								09/08/2021
								

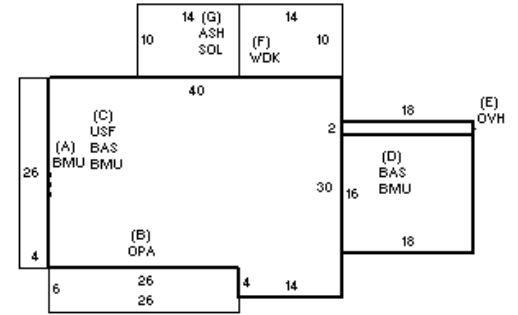

BUILDING

BUILDING	CD	ADJ	DESC	MEASURE	9/8/2021	RP
MODEL	1		RESIDENTIAL	LIST	9/8/2021	EST
STYLE	5	1.00	COLONIAL [100%]	REVIEW	9/8/2021	RP
QUALITY	G	1.10	GOOD [100%]			
FRAME	1	1.00	WOOD FRAME [100%]			

BLDG COMMENTS		

INDING

YEAR BLT	2000	SIZE ADJ	1.000
NET AREA	2,516	DETAIL ADJ	1.000
\$NLA(RCN)	\$238	OVERALL	1.090
CAPACITY		UNITS	ADJ
STORIES	2	1.00	
ROOMS	7	1.00	
BEDROOMS	4	1.00	
BATHROOMS	2	1.00	
FIXTURES	12	1.00	
GARAGE CAPACITY	2	1.00	
% BSMT FINISH	0	1.00	
# OF HALF BATHS	1	1.00	
# OF UNITS	1	1.00	

ELEMENT	CD	DESCRIPTION	ADJ	S	BAT	T	DESCRIPTION	UNITS	YB	ADJ PRICE	RCN
FOUNDATION	4	FLR/WALL(FULL)	1.00	+	BMU	N	BSMT UNFINISHED	1,488		38.30	56,996
EXT COVER	1	WOOD SHINGLE	1.02	B	OPA	N	OPEN PORCH	156		78.37	12,225
ROOF SHAPE	2	HIP	1.02	+	BAS	L	BASE AREA	1,384	2000	225.39	311,940
ROOF COVER	1	ASPH/COMP SHIN	1.00	C	USF	L	UPPER STORY FIN	1,096	2000	124.66	136,625
FLOOR COVER	1	HARDWOOD	1.02	E	OVH	L	OVERHANG	36	2000	217.15	7,818
INT. FINISH	2	DRYWALL	1.00	F	WDK	N	WOOD DECK	140		47.38	6,633
HEATING/COOLING	9	WARM-COOL AIR	1.03	G	SOL	N	SOLARIUM	140		123.15	17,240
FUEL SOURCE	1	OIL	1.00	G	ASH	N	ATT SHED	140		27.80	3,892
USE	0		1.00	BMG	O		BSMT GARAGE	2		8,546.45	17,093
				F21	O		FPL 2S 1OP	1		10,562.00	10,562
				FIX	O		XTRA FIXTURES	7		2,553.36	17,874

TOTAL RCN	598,897
CONDITION ELEM	CD
EXTERIOR	A
INTERIOR	A
KITCHEN	A
BATHS	A
HEAT	A
ELECT	A
EFF.YR/AGE	2002 / 20
COND	17 17 %
FUNC	0
ECON	0
DEPR	17 % GD 83
RCNLD	\$497,100