

Key: 1787

Town of Bourne - Fiscal Year 2024

12/18/2023 6:02 pm SEQ #: 1.803

LEGAL

CURRENT OWNER		PARCEL ID	LOCATION		
MAXIM MICHAEL J & JANET M TRS MAXIM TRUST PO BOX 439 BUZZARDS BAY, MA 02532		11.0-9-0	8 HERRING POND RD		
TRANSFER HISTORY		DOS	T	SALE PRICE	BK-PG (Cert)
MAXIM MICHAEL J & JANET M		01/25/2019	F	1 31801-9	
MAXIM MICHAEL J TR OF		06/01/2001	F	1 13893-291	
MAXIM MICHAEL J &		06/01/2001	F	1 13893-270	

CLASS	CLASS%	DESCRIPTION		BN ID	BN	CARD	
1110	100	APT - 4 TO 8 UNITS			1	1 of 2	
PMT NO	PMT DT	TY	DESC	AMOUNT	INSP	BY	1st %
04856	11/23/2004	3	ALT/RENO	2,500	09/15/2006	DB	100 100

LAND

CD	T	AC/SF/UN	Nbhd	Infl1	N Index	ADJ BASE	SAF	Topo	Lpi	VC	CREDIT AMT	ADJ VALUE
112	U		4 APT	1.00	100 1.00	66,240	1.00	A	1.00	APV	1.80	264,960

TOTAL	18,382 SF	ZONING	2	FRNT	110	ASSESSED	CURRENT	PREVIOUS
Nbhd	APTS	NOTE Property faces scenic highway; views of canal	LAND	265,000	252,000			
Infl1	AVG		BUILDING	302,100	267,400			
N_Index	AVG		DETACHED	0	0			
			OTHER	65,900	58,400			
			TOTAL	633,000	577,800			

DETACHED

TY	QUAL	COND	DIM/NOTE	YB	UNITS	ADJ PRICE	RCNLD
SHF	L	0.90 F	0.60 6 X 6			0.00	



BLDG COMMENTS

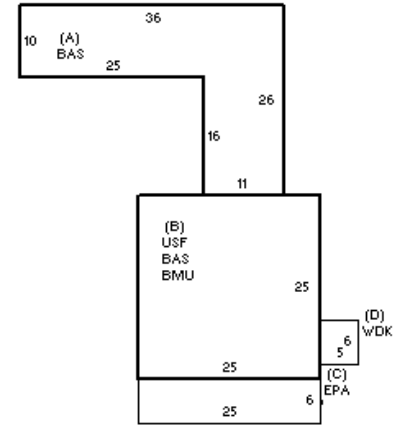

BUILDING

BUILDING	CD	ADJ	DESC	MEASURE	7/27/2021	RP
MODEL	1		RESIDENTIAL	LIST	7/27/2021	EST
STYLE	7	1.00	CONVENTIONAL [100%]	REVIEW	7/27/2021	RP
QUALITY	A	1.00	AVERAGE [100%]			
FRAME	1	1.00	WOOD FRAME [100%]			

YEAR BLT	1900	SIZE ADJ	1.010
NET AREA	1,786	DETAIL ADJ	1.000
\$NLA(RCN)	\$229	OVERALL	1.120
CAPACITY		UNITS	ADJ
STORIES	2	1.00	
ROOMS	10	1.00	
BEDROOMS	4	1.00	
BATHROOMS	3	1.00	
FIXTURES	13	1.00	
GARAGE CAPACITY	0	1.00	
% BSMT FINISH	0	1.00	
# OF HALF BATHS	0	1.00	
# OF UNITS	3	1.10	

ELEMENT	CD	DESCRIPTION	ADJ	S	BAT	T	DESCRIPTION	UNITS	YB	ADJ PRICE	RCN
FOUNDATION	4	FLR/WALL(FULL)	1.00	+	BAS	L	BASE AREA	1,161	1900	217.15	252,114
EXT COVER	2	CLAPBOARD	1.00	B	BMU	N	BSMT UNFINISHED	625		52.07	32,545
ROOF SHAPE	1	GABLE	1.00	B	USF	L	UPPER STORY FIN	625	1900	123.00	76,874
ROOF COVER	1	ASPH/COMP SHIN	1.00	C	EPA	N	ENCLOSED PORCH	150		93.06	13,959
FLOOR COVER	3	W/W CARPET	1.00	D	WDK	N	WOOD DECK	30		71.72	2,152
INT. FINISH	2	DRYWALL	1.00		FIX	O	XTRA FIXTURES	8		2,409.04	19,272
HEATING/COOLING	2	HOT WATER	1.02		KIT	O	EXTRA KITCHEN	2		5,681.45	11,363
FUEL SOURCE	2	GAS	1.00								
USE	0		1.00								

TOTAL RCN	408,278
CONDITION ELEM	CD
EXTERIOR	A
INTERIOR	F
KITCHEN	A
BATHS	A
HEAT	A
ELECT	A
EFF.YR/AGE	1993 / 29
COND	26 26 %
FUNC	0
ECON	0
DEPR	26 % GD 74
RCNLD	\$302,100

Key: 1787

Town of Bourne - Fiscal Year 2024

12/18/2023 6:02 pm SEQ #: 1.804

LEGAL

CURRENT OWNER		PARCEL ID	LOCATION			
MAXIM MICHAEL J & JANET M TRS MAXIM TRUST PO BOX 439 BUZZARDS BAY, MA 02532		11.0-9-0	8 HERRING POND RD			
TRANSFER HISTORY		DOS	T	SALE PRICE	BK-PG (Cert)	

CLASS	CLASS%	DESCRIPTION			BN ID	BN	CARD
1110	100	APT - 4 TO 8 UNITS				2	2 of 2
PMT NO	PMT DT	TY	DESC	AMOUNT	INSP	BY	1st %

LAND

CD	T	AC/SF/UN	Nbhd	Infl1	N Index	ADJ BASE	SAF	Topo	Lpi	VC	CREDIT AMT	ADJ VALUE

TOTAL	ZONING	FRNT	ASSESSED	CURRENT	PREVIOUS
Nbhd	NOTE		LAND	65,900	
Infl1		BUILDING			
N_Index		DETACHED			
			OTHER		
			TOTAL		

DETACHED

TY	QUAL	COND	DIM/NOTE	YB	UNITS	ADJ PRICE	RCNLD	PHOTO
								12/31/2002

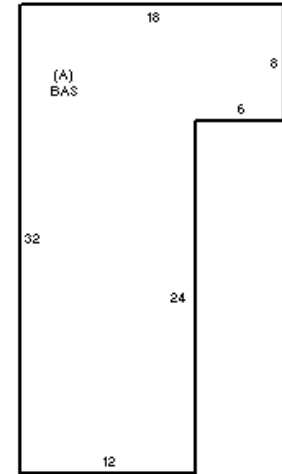
BUILDING

BUILDING	CD	ADJ	DESC	MEASURE	7/27/2021	RP
MODEL	1		RESIDENTIAL	LIST	7/27/2021	EST
STYLE	1	0.95	RANCH [100%]	REVIEW	7/27/2021	RP
QUALITY	A	1.00	AVERAGE [100%]			
FRAME	1	1.00	WOOD FRAME [100%]			

YEAR BLT	1940	SIZE ADJ	1.000	ELEMENT	CD	DESCRIPTION	ADJ	S	BAT	T	DESCRIPTION	UNITS	YB	ADJ PRICE	RCN
NET AREA	432	DETAIL ADJ	1.000	FOUNDATION	3	FOUN. WALL	1.00	A	BAS	L	BASE AREA	432	1940	206.28	89,114
\$NLA(RCN)	\$206	OVERALL	0.950	EXT COVER	1	WOOD SHINGLE	1.02								
CAPACITY		UNITS	ADJ	ROOF SHAPE	1	GABLE	1.00								
STORIES		1	1.00	ROOF COVER	1	ASPH/COMP SHIN	1.00								
ROOMS		3	1.00	FLOOR COVER	3	W/W CARPET	1.00								
BEDROOMS		1	1.00	INT. FINISH	2	DRYWALL	1.00								
BATHROOMS		1	1.00	HEATING/COOLING	5	ELECTRIC BB	0.98								
FIXTURES		5	1.00	FUEL SOURCE	3	ELECTRIC	1.00								
GARAGE CAPACITY		0	1.00	USE	0		1.00								
% BSMT FINISH		0	1.00												
# OF HALF BATHS		0	1.00												
# OF UNITS		1	1.00												

TOTAL RCN	89,114	
CONDITION ELEM	CD	
EXTERIOR	A	
INTERIOR	F	
KITCHEN	A	
BATHS	A	
HEAT	A	
ELECT	A	
EFF.YR/AGE	1993 / 29	
COND	26	26 %
FUNC	0	
ECON	0	
DEPR	26	% GD 74
RCNLD	\$65,900	