

Key: 1933

Town of Bourne - Fiscal Year 2024

12/18/2023 6:02 pm SEQ #: 1.946

LEGAL

LAND

CURRENT OWNER				PARCEL ID				LOCATION			
RUGGERI RICHARD S & NANCY I & MARYELLEN E HUNTER PO BOX 1448 SAGAMORE BEACH, MA 02562-1448				11.0-164-0				7 BRIGANTINE PASSAGE DR			
TRANSFER HISTORY				DOS	T	SALE PRICE		BK-PG (Cert)			
RUGGERI RICHARD S & NANCY				12/10/2012	F	1 (198932)					
RUGGERI RICHARD S AND				04/06/1998	P	60,000 (148017)					
J.A.S. INVESTMENTS INC.				12/31/1993	B	150,000 N/A-N/A					

CLASS	CLASS%	DESCRIPTION			BN ID	BN	CARD	
1010	100	SINGLE FAMILY				1	1 of 1	
PMT NO	PMT DT	TY	DESC	AMOUNT	INSP	BY	1st	%
980245	05/18/1998	1	NEW CONSTRUC	90,000	11/20/2001	TL	100	100

CD	T	AC/SF/UN	Nbhd	Inf1	N	Index	ADJ BASE	SAF	Topo	Lpi	VC	CREDIT AMT	ADJ VALUE
100	S	40,000	3	1.00	100	1.00	188,560	1.00	A	1.00	R02	0.80	173,120
300	A	0.125	3	1.00	100	1.00	13,040	1.00	A	1.00	R02	0.80	1,630

TOTAL	1.043 Acres	ZONING	1	FRNT	150	ASSESSED	CURRENT	PREVIOUS
Nbhd	BDALE	N O T E	PARTIAL VIEW OF BRIDGE FROM ROOF DECKS			LAND	174,800	154,700
Inf1	AVG		BUILDING	782,100	688,200			
N_Index	AVG		DETACHED	0	0			
			OTHER	0	0			
			TOTAL	956,900	842,900			

TY	QUAL	COND	DIM/NOTE	YB	UNITS	ADJ PRICE	RCNLD



BLDG COMMENTS

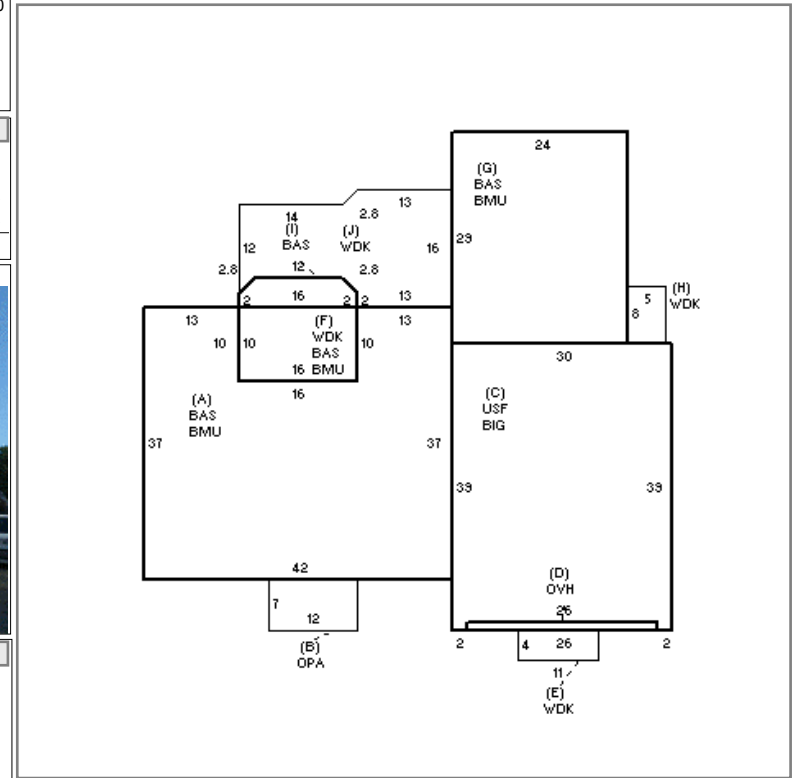

DETACHED

BUILDING

BUILDING	CD	ADJ	DESC	MEASURE	10/19/2022	SL
MODEL	1		RESIDENTIAL	LIST	1/30/2023	EST
STYLE	8	1.10	CONTEMPORARY [100%]	REVIEW	1/30/2023	TL
QUALITY	G	1.10	GOOD [100%]			
FRAME	1	1.00	WOOD FRAME [100%]			

YEAR BLT	1998	SIZE ADJ	0.995	ELEMENT	CD	DESCRIPTION	ADJ
NET AREA	3,480	DETAIL ADJ	1.000	FOUNDATION	4	FLR/WALL(FULL)	1.00
\$NLA(RCN)	\$274	OVERALL	1.150	EXT COVER	2	CLAPBOARD	1.00
CAPACITY		UNITS	ADJ	ROOF SHAPE	1	GABLE	1.00
STORIES	2	1.00		ROOF COVER	1	ASPH/COMP SHIN	1.00
ROOMS	6	1.00		FLOOR COVER	6	TILE	1.02
BEDROOMS	5	1.00		INT. FINISH	2	DRYWALL	1.00
BATHROOMS	4	1.00		HEATING/COOLING	9	WARM-COOL AIR	1.03
FIXTURES	15	1.00		FUEL SOURCE	2	GAS	1.00
GARAGE CAPACITY	2	1.00		USE	0		1.00
% BSMT FINISH	0	1.00					
# OF HALF BATHS	0	1.00					
# OF UNITS	0	1.00					

S	BAT	T	DESCRIPTION	UNITS	YB	ADJ PRICE	RCN
+	BMU	N	BSMT UNFINISHED	2,250		36.17	81,376
B	OPA	N	OPEN PORCH	84		90.46	7,599
C	BIG	N	BUILT-IN GARAGE	1,144		88.10	100,785
C	USF	L	UPPER STORY FIN	1,144	1998	130.86	149,706
D	OVH	L	OVERHANG	26	1998	227.97	5,927
+	WDK	N	WOOD DECK	618		26.88	16,615
+	BAS	L	BASE AREA	2,310	1998	216.32	499,702
	USU	N	UPPER STORY UNF	481		58.95	28,357
	WDK	N	WOOD DECK	256		32.60	8,345
	FIX	O	XTRA FIXTURES	10		2,680.47	26,805
	GFP	O	GAS FIREPLACE	1		8,055.50	8,056
	JAC	O	JACUZZI	1		15,456.50	15,457
	MST	O	MAS/METAL STACK	1		5,023.40	5,023

TOTAL RCN	953,750
CONDITION ELEM	CD
EXTERIOR	A
INTERIOR	A
KITCHEN	A
BATHS	A
HEAT	A
ELECT	A
EFF.YR/AGE	2001 / 21
COND	18 18 %
FUNC	0
ECON	0
DEPR	18 % GD 82
RCNLD	\$782,100