

Key: 1963

Town of Bourne - Fiscal Year 2024

12/18/2023 6:02 pm SEQ #: 1.975

LEG
A
L
L
A
N
D

CURRENT OWNER				PARCEL ID				LOCATION			
SAMPSON DAVID P 791 SANDWICH RD BOURNE, MA 02532				11.4-2-0				791 SANDWICH RD			
TRANSFER HISTORY				DOS	T	SALE PRICE	BK-PG (Cert)				
SAMPSON DAVID P				08/30/2021	F	1	34421-218				
SAMPSON DAVID P				09/19/2003	H	200,000	17674-282				
CLEMENT SPILLANE ADMIN				06/12/2003	X		17074-34				

CLASS	CLASS%	DESCRIPTION			BN ID	BN	CARD	
1010	100	SINGLE FAMILY				1	1 of 1	
PMT NO	PMT DT	TY	DESC	AMOUNT	INSP	BY	1st	%
B-23-17	03/16/2023	2	ADDITIONS	15,000	06/20/2023	SL	100	100
18370	05/07/2018	4	DETACH.STRUC	10,000	07/31/2019	RP	100	100
990326	06/14/1999	3	ALT/RENO	3,500	10/29/1999	MS	100	100

CD	T	AC/SF/UN	Nbhd	Infl1	N Index	ADJ BASE	SAF	Topo	Lpi	VC	CREDIT AMT	ADJ VALUE					
100	S	17,000	2	1.00	100	1.00	100	1.00	235,700	1.96	A	1.00	CVW	1.00			180,300

TOTAL	16,988 SF	ZONING	1	FRNT	203	ASSESSED	CURRENT	PREVIOUS
Nbhd	S SAG	NOTE	LAND	180,300	159,600			
Infl1	AVG		BUILDING	239,400	202,800			
N_Index	AVG		DETACHED	11,800	11,300			
			OTHER	0	0			
TOTAL			431,500	373,700				

TY	QUAL	COND	DIM/NOTE	YB	UNITS	ADJ PRICE	RCNLD
SHF	A	1.00	50 0.50 8 X 12			0.00	
DGF	A	1.00	10 0.90 14 X 20	2019	280	46.93	11,800

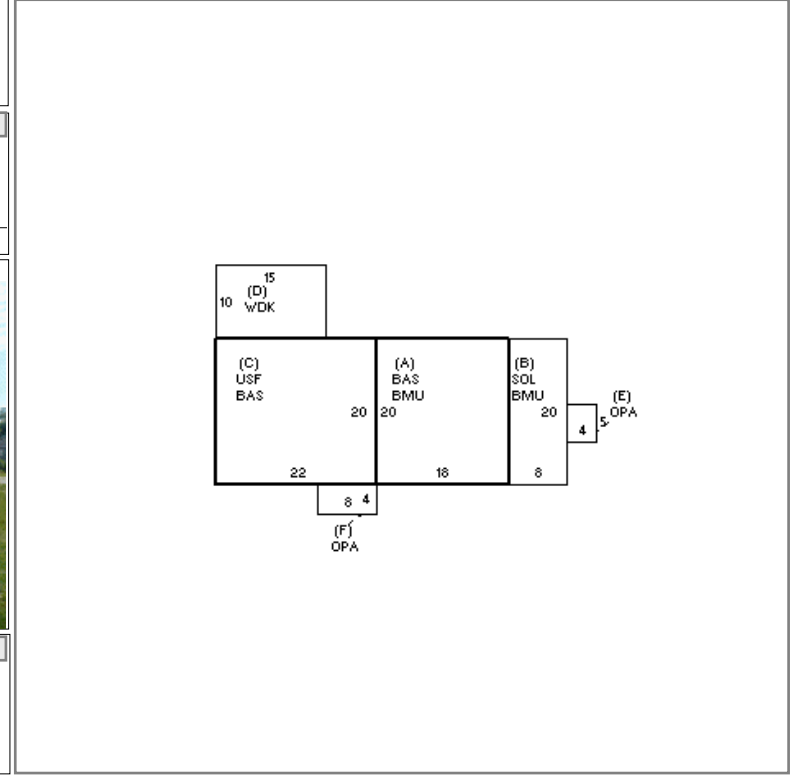

BUILDING	CD	ADJ	DESC	MEASURE	6/20/2023	SL
MODEL	1		RESIDENTIAL	LIST	6/20/2023	EST
STYLE	7	1.00	CONVENTIONAL [100%]	REVIEW	6/20/2023	SL
QUALITY	A	1.00	AVERAGE [100%]			
FRAME	1	1.00	WOOD FRAME [100%]			

BLDG COMMENTS

D
E
T
A
C
H
E
D

B
U
I
L
D
I
N
G

YEAR BLT	1920	SIZE ADJ	1.015	ELEMENT	CD	DESCRIPTION	ADJ	S	BAT	T	DESCRIPTION	UNITS	YB	ADJ PRICE	RCN	TOTAL RCN	291,928		
NET AREA	1,240	DETAIL ADJ	1.000	FOUNDATION	4	FLR/WALL(FULL)	1.00	+	BMU	N	BSMT UNFINISHED	520		49.06	25,510	CONDITION ELEM	CD		
\$NLA(RCN)	\$235	OVERALL	1.050	EXT COVER	15	VINYL SHINGLE	1.02	B	SOL	N	SOLARIUM	160		102.15	16,343	EXTERIOR	G		
				ROOF SHAPE	1	GABLE	1.00	+	BAS	L	BASE AREA	800	1920	219.83	175,868	INTERIOR	A		
				ROOF COVER	1	ASPH/COMP SHIN	1.00	C	USF	L	UPPER STORY FIN	440	1920	117.27	51,597	KITCHEN	G		
				FLOOR COVER	3	W/W CARPET	1.00	D	WDK	N	WOOD DECK	150		42.11	6,317	BATHS	G		
				INT. FINISH	1	PLASTER	1.00	+	OPA	N	OPEN PORCH	52		81.67	4,247	HEAT	A		
				HEATING/COOLING	9	WARM-COOL AIR	1.03		CRL	N	BSMT CRAWL	440		27.38	12,046	ELECT	A		
				FUEL SOURCE	2	GAS	1.00												
				USE	0		1.00												
																		EFF.YR/AGE	2001 / 21
																		COND	18 18 %
																		FUNC	0
																		ECON	0
																		DEPR	18 % GD 82
																		RCNLD	\$239,400