

Key: 1965

Town of Bourne - Fiscal Year 2024

12/18/2023 6:02 pm SEQ #: 1.977

LEGAL

LAND

DETACHED

BUILDING

CURRENT OWNER		PARCEL ID		LOCATION	
WILBUR DARREN P & DIANE D WILBUR PO BOX 233 SAGAMORE, MA 02561		11.4-4-0		799 SANDWICH RD	
TRANSFER HISTORY		DOS	T	SALE PRICE	BK-PG (Cert)
WILBUR DARREN P & WILBUR GARY M		08/10/2021 01/29/1988	A XX	350,000	N/A-N/A 968-62

CLASS	CLASS%	DESCRIPTION		BN ID	BN	CARD	
1010	100	SINGLE FAMILY			1	1 of 1	
PMT NO	PMT DT	TY	DESC	AMOUNT	INSP	BY	1st %
EXB-22-435	07/14/2022	3	ALT/RENO	13,464	01/12/2023	SL	100 100
09376	08/11/2009	3	SOLAR		10/09/2009	TL	100 100
05703	10/11/2005	3	ALT/RENO	12,000	01/23/2007	TL	100 100
960563	11/13/1996	3	ALT/RENO	1,688	04/25/1997	JC	100 100

CD	T	AC/SF/UN	Nbhd	Infl1	N Index	ADJ BASE	SAF	Topo	Lpi	VC	CREDIT AMT	ADJ VALUE
100	S	12,450	2	1.00	100 1.00	235,700	2.57	A	1.00	CVW	1.00	173,160

TOTAL	12,458 SF	ZONING	1	FRNT	120	ASSESSED	CURRENT	PREVIOUS
Nbhd	S SAG	NOTE	LAND	173,200	153,300			
Infl1	AVG		BUILDING	289,600	257,800			
N_Index	AVG		DETACHED	2,800	0			
			OTHER	0	0			
			TOTAL	465,600	411,100			

TY	QUAL	COND	DIM/NOTE	YB	UNITS	ADJ PRICE	RCNLD
SHF	L	0.90	50 0.50		308	13.28	2,000
SHF	L	0.90	50 0.50		112	14.78	800

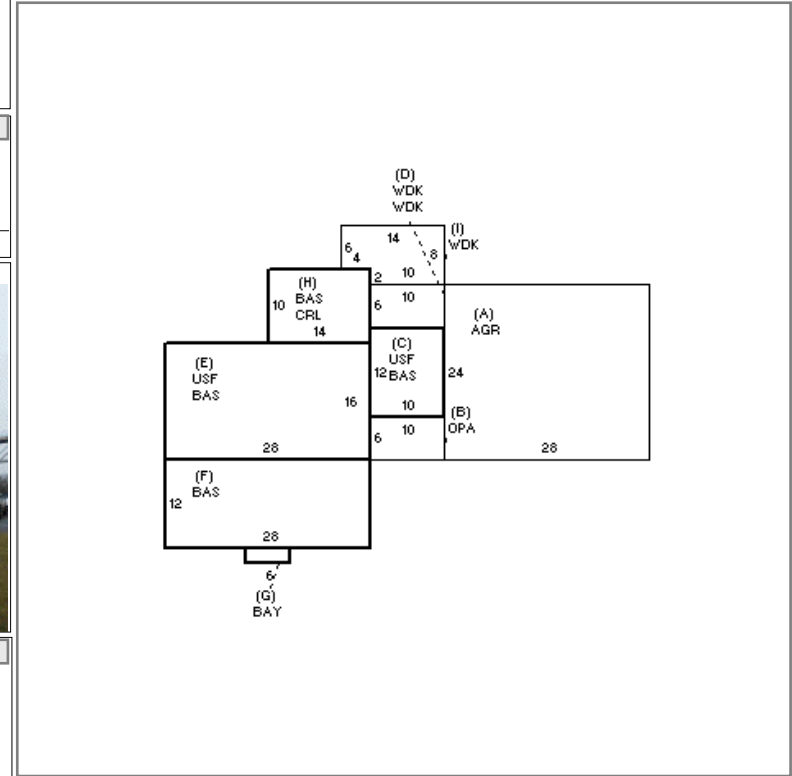

BUILDING	CD	ADJ	DESC	MEASURE	1/12/2023	SL
MODEL	1		RESIDENTIAL	LIST	1/18/2023	SL
STYLE	7	1.00	CONVENTIONAL [100%]	REVIEW	1/18/2023	SL
QUALITY	A	1.00	AVERAGE [100%]			
FRAME	1	1.00	WOOD FRAME [100%]			

BLDG COMMENTS

YEAR BLT	1957	SIZE ADJ	1.010	ELEMENT	CD	DESCRIPTION	ADJ	S	BAT	T	DESCRIPTION	UNITS	YB	ADJ PRICE	RCN	TOTAL RCN	381,072		
NET AREA	1,624	DETAIL ADJ	1.000	FOUNDATION	4	FLR/WALL(FULL)	1.00	A	AGR	N	ATT GARAGE	672		61.06	41,035	CONDITION ELEM	CD		
\$NLA(RCN)	\$235	OVERALL	1.040	EXT COVER	1	WOOD SHINGLE	1.02	B	OPA	N	OPEN PORCH	60		80.50	4,830	EXTERIOR	A		
				ROOF SHAPE	1	GABLE	1.00	+	BAS	L	BASE AREA	1,044	1957	201.64	210,514	INTERIOR	A		
				ROOF COVER	1	ASPH/COMP SHIN	1.00	+	USF	L	UPPER STORY FIN	568	1957	115.58	65,649	KITCHEN	A		
				FLOOR COVER	5	VINYL	1.00	+	WDK	N	WOOD DECK	224		27.20	6,093	BATHS	A		
				INT. FINISH	2	DRYWALL	1.00	G	BAY	L	BAY/WINDOW	12	1957	190.21	2,283	HEAT	A		
				HEATING/COOLING	2	HOT WATER	1.02	H	CRL	N	BSMT CRAWL	140		35.98	5,038	ELECT	A		
				FUEL SOURCE	1	OIL	1.00	BMU	N	BSMT UNFINISHED	672		48.35	32,492					
				USE	0		1.00	FIX	O	XTRA FIXTURES	4		2,236.83	8,947					
								MST	O	MAS/METAL STACK	1		4,192.10	4,192					
																		EFF.YR/AGE	1995 / 27
																		COND	24 24 %
																		FUNC	0
																		ECON	0
																		DEPR	24 % GD 76
																		RCNLD	\$289,600