

Key: 2048

Town of Bourne - Fiscal Year 2024

12/18/2023 6:02 pm SEQ #: 2.059

LEG
AL

CURRENT OWNER				PARCEL ID				LOCATION			
CONSONI ROBERT PO BOX 1 SAGAMORE, MA 02561				11.4-101-0				21 COMMONWEALTH AVE			
TRANSFER HISTORY				DOS	T	SALE PRICE	BK-PG (Cert)				
CONSONI ROBERT CONSONI OLGA				05/24/2006	F XX	100	21028-285 (61227)				

LAN
D

CD	T	AC/SF/UN	Nbhd	Infl1	N Index	ADJ BASE	SAF	Topo	Lpi	VC	CREDIT AMT	ADJ VALUE	
100	S	11,793 2	1.00	100	1.00	100	1.00	212,130	2.70	A	1.00	R04 0.90	154,920

TOTAL	11,805 SF	ZONING	1	FRNT	98	ASSESSED	CURRENT	PREVIOUS
Nbhd	S SAG	NOTE Also 120' frontage on West St	LAND	154,900	137,100			
Infl1	AVG		BUILDING	256,200	226,700			
N_Index	AVG		DETACHED	0	0			
			OTHER	0	0			
				TOTAL	411,100	363,800		

DET
ACH
ED

TY	QUAL	COND	DIM/NOTE	YB	UNITS	ADJ PRICE	RCNLD



CLASS	CLASS%	DESCRIPTION	BN ID	BN	CARD			
1010	100	SINGLE FAMILY		1	1 of 1			
PMT NO	PMT DT	TY	DESC	AMOUNT	INSP	BY	1st	%

B
U
I
L
D
I
N
G

BUILDING	CD	ADJ	DESC	MEASURE	12/13/2022	SL
MODEL	1		RESIDENTIAL	LIST	12/13/2022	EST
STYLE	1	0.95	RANCH [100%]	REVIEW	12/13/2022	SL
QUALITY	A	1.00	AVERAGE [100%]			
FRAME	1	1.00	WOOD FRAME [100%]			

BLDG COMMENTS

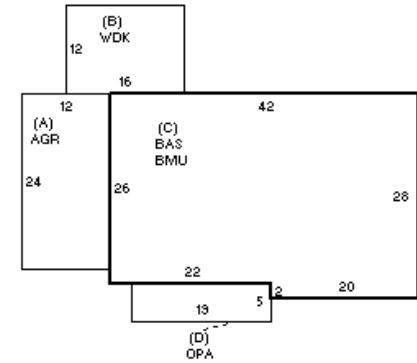

YEAR BLT	1961	SIZE ADJ	1.015
NET AREA	1,132	DETAIL ADJ	1.000
\$NLA(RCN)	\$263	OVERALL	0.990
CAPACITY		UNITS	ADJ
STORIES	1	1.00	
ROOMS	5	1.00	
BEDROOMS	2	1.00	
BATHROOMS	1	1.00	
FIXTURES	7	1.00	
GARAGE CAPACITY	1	1.00	
% BSMT FINISH	0	1.00	
# OF HALF BATHS	1	1.00	
# OF UNITS	1	1.00	

ELEMENT	CD	DESCRIPTION	ADJ
FOUNDATION	4	FLR/WALL(FULL)	1.00
EXT COVER	4	VINYL	1.00
ROOF SHAPE	1	GABLE	1.00
ROOF COVER	1	ASPH/COMP SHIN	1.00
FLOOR COVER	1	HARDWOOD	1.02
INT. FINISH	2	DRYWALL	1.00
HEATING/COOLING	2	HOT WATER	1.02
FUEL SOURCE	1	OIL	1.00
USE	0		1.00

S	BAT	T	DESCRIPTION	UNITS	YB	ADJ PRICE	RCN
A	AGR	N	ATT GARAGE	288		70.13	20,199
B	WDK	N	WOOD DECK	192		35.15	6,749
C	BMU	N	BSMT UNFINISHED	1,132		36.64	41,478
C	BAS	L	BASE AREA	1,132	1961	192.90	218,360
D	OPA	N	OPEN PORCH	95		72.21	6,860
	FIX	O	XTRA FIXTURES	2		2,139.85	4,280

TOTAL RCN	297,925
CONDITION ELEM	CD
EXTERIOR	G
INTERIOR	A
KITCHEN	A
BATHS	A
HEAT	U
ELECT	U
EFF.YR/AGE	2005 / 17
COND	14 14 %
FUNC	0
ECON	0
DEPR	14 % GD 86
RCNLD	\$256,200