

Key: 2157

Town of Bourne - Fiscal Year 2024

12/18/2023 6:02 pm SEQ #: 2.168

Table with columns: CURRENT OWNER, PARCEL ID, LOCATION. Includes owner name 'DOUCETTE SUSAN & RAYMOND TRS' and parcel ID '12.1-67-0'.

Table with columns: CLASS, CLASS%, DESCRIPTION, BN ID, BN, CARD. Lists various solar and pool installations with dates and amounts.

Table with columns: CD, T, AC/SF/UN, Nbhd, Infil1, N Index, ADJ BASE, SAF, Topo, Lpi, VC, CREDIT AMT, ADJ VALUE. Provides detailed property metrics and values.

Table with columns: TOTAL, ZONING, FRNT, ASSESSED, CURRENT, PREVIOUS. Summarizes total area, zoning (N SAG), and assessed values.

Table with columns: TY, QUAL, COND, DIM/NOTE, YB, UNITS, ADJ PRICE, RCNLD. Lists property types like IPG, SHF with their respective conditions and dimensions.

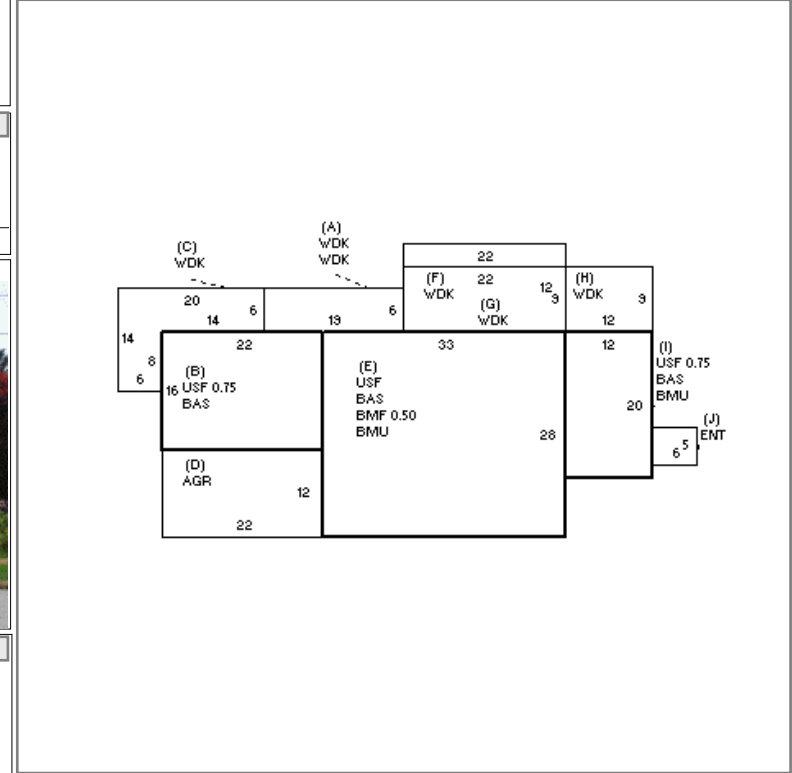

Table with columns: BUILDING, CD, ADJ, DESC, MEASURE, 7/9/2021, NMP. Details building characteristics and measurement dates.

BLDG COMMENTS section for additional notes on the building.

Main summary table with columns: YEAR BLT, NET AREA, \$NLA(RCN), CAPACITY, ELEMENT, CD, DESCRIPTION, ADJ, S, BAT, T, DESCRIPTION, UNITS, YB, ADJ PRICE, RCN, TOTAL RCN, 636.887. Includes detailed breakdown of building elements and costs.