

Key: 2359

Town of Bourne - Fiscal Year 2024

12/18/2023 6:02 pm SEQ #: 2.383

LEG  
A  
L  
  
L  
A  
N  
D

CURRENT OWNER		PARCEL ID	LOCATION		
MCNAMARA BRIAN W PO BOX 131 SAGAMORE, MA 02561		12.4-18-0	1049 SANDWICH RD		
TRANSFER HISTORY		DOS	T	SALE PRICE	BK-PG (Cert)
MCNAMARA BRIAN W		05/29/1992	A	120,000	08043-00185
MCNAMARA BRIAN W			XX		N/A-N/A

CLASS	CLASS%	DESCRIPTION			BN ID	BN	CARD	
1010	100	SINGLE FAMILY				1	1 of 1	
PMT NO	PMT DT	TY	DESC	AMOUNT	INSP	BY	1st	%
0894	09/17/2008	10	WOODSTOVE		06/15/2009		100	100
930201	05/12/1993	6	FENCE	100	03/21/1994	JS	100	100

CD	T	AC/SF/UN	Nbhd	Infl1	N Index	ADJ BASE	SAF	Topo	Lpi	VC	CREDIT AMT	ADJ VALUE					
100	S	17,600	2	1.00	100	1.00	100	1.00	212,130	1.90	A	1.00	R06	0.90			163,120

TOTAL	17,598 SF	ZONING	1	FRNT	85	ASSESSED	CURRENT	PREVIOUS
Nbhd	S SAG	NOTE				LAND	163,100	144,400
Infl1	AVG		BUILDING	327,200	296,800			
N_Index	AVG		DETACHED	0	4,200			
			OTHER	0	0			
						TOTAL	490,300	445,400

TY	QUAL	COND	DIM/NOTE	YB	UNITS	ADJ PRICE	RCNLD
DGF	F	0.70	80	0.20	13X20		
						0.00	



BLDG COMMENTS

BUILDING	CD	ADJ	DESC	MEASURE	2/16/2023	SL
MODEL	1		RESIDENTIAL	LIST	2/16/2023	EST
STYLE	7	1.00	CONVENTIONAL [100%]	REVIEW	2/16/2023	SL
QUALITY	A	1.00	AVERAGE [100%]			
FRAME	1	1.00	WOOD FRAME [100%]			

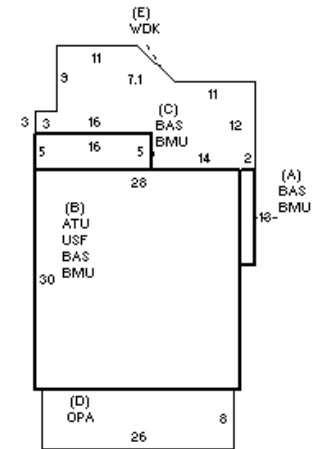

D  
E  
T  
A  
C  
H  
E  
D

B  
U  
I  
L  
D  
I  
N  
G

YEAR BLT	1910	SIZE ADJ	1.010	ELEMENT	CD	DESCRIPTION	ADJ	S	BAT	T	DESCRIPTION	UNITS	YB	ADJ PRICE	RCN	TOTAL RCN	408,963
NET AREA	1,786	DETAIL ADJ	1.000	FOUNDATION	4	FLR/WALL(FULL)	1.00	+	BMU	N	BSMT UNFINISHED	946		39.78	37,628	CONDITION ELEM	CD
\$NLA(RCN)	\$229	OVERALL	1.080	EXT COVER	1	WOOD SHINGLE	1.02	+	BAS	L	BASE AREA	946	1910	216.31	204,630	EXTERIOR	A
				ROOF SHAPE	2	HIP	1.02	B	USF	L	UPPER STORY FIN	840	1910	117.42	98,637	INTERIOR	A
				ROOF COVER	1	ASPH/COMP SHIN	1.00	B	ATU	N	ATTIC UNF	840		45.10	37,888	KITCHEN	A
				FLOOR COVER	2	SOFTWOOD	1.02	D	OPA	N	OPEN PORCH	208		64.19	13,353	BATHS	A
				INT. FINISH	1	PLASTER	1.00	E	WDK	N	WOOD DECK	336		23.30	7,829	HEAT	U
				HEATING/COOLING	2	HOT WATER	1.02	FIX	O	XTRA FIXTURES	2			2,322.85	4,646	ELECT	A
				FUEL SOURCE	1	OIL	1.00	MST	O	MAS/METAL STACK	1			4,353.40	4,353		
				USE	0		1.00										
				EFF.YR/AGE 1999 / 23													
				COND 20 20 %													
				FUNC 0													
				ECON 0													
				DEPR 20 % GD 80													
				RCNLD \$327,200													