

Key: 2751

Town of Bourne - Fiscal Year 2024

12/18/2023 6:02 pm SEQ #: 2.777

LEG  
AL  
LAND

| CURRENT OWNER   |   |          |      | PARCEL ID  |         |            |              | LOCATION               |      |     |            |           |
|---|---|----------|------|------------|---------|------------|--------------|------------------------|------|-----|------------|-----------|
| COSTA KEITH E<br>680 HEAD OF THE BAY RD<br>BUZZARDS BAY, MA 02532 |   |          |      | 14.0-81-0  |         |            |              | 680 HEAD OF THE BAY RD |      |     |            |           |
| TRANSFER HISTORY  |   |          |      | DOS        | T       | SALE PRICE | BK-PG (Cert) |                        |      |     |            |           |
| COSTA KEITH E   |   |          |      | 08/30/2019 | U       | 350,000    | 32261-85     |                        |      |     |            |           |
| TRAVERS LAURIE J  |   |          |      | 03/22/2019 | F       | 1          | 31902-76     |                        |      |     |            |           |
| GRESH LEE   |   |          |      | 03/15/2010 | F       | 100        | 24417-334    |                        |      |     |            |           |
| CD  | T | AC/SF/UN | Nbhd | Infl1      | N Index | ADJ BASE   | SAF          | Topo                   | Lpi  | VC  | CREDIT AMT | ADJ VALUE |
| 100   | S | 80,000   | 4    | 1.00       | 100     | 188,560    | 0.64         | A                      | 1.00 | R01 | 0.80       | 223,330   |
| 300   | A | 1,394    | 4    | 1.00       | 100     | 13,040     | 1.00         | A                      | 1.00 | R01 | 0.80       | 18,180    |

| CLASS  | CLASS%     | DESCRIPTION   |              |         | BN ID      | BN | CARD   |     |
|--------|------------|---------------|--------------|---------|------------|----|--------|-----|
| 1010   | 100        | SINGLE FAMILY |              |         |            | 1  | 1 of 1 |     |
| PMT NO | PMT DT     | TY            | DESC         | AMOUNT  | INSP       | BY | 1st    | %   |
| 07343  | 06/18/2007 | 4             | DETACH.STRUC | 3,000   | 07/14/2009 |    | 100    | 100 |
| 07297  | 06/01/2007 | 10            | WOODSTOVE    | 3,000   | 07/14/2009 |    | 100    | 100 |
| 05043  | 01/31/2005 | 1             | NEW CONSTRUC | 300,000 | 09/11/2006 | TL | 100    | 100 |
|        |            | 13            | OTHER        |         |            |    | 100    | 100 |

LAND

| TOTAL   | 3.231 Acres |  | ZONING | 2        | FRNT    | 181     | ASSESSED | CURRENT | PREVIOUS |
|---------|-------------|--|--------|----------|---------|---------|----------|---------|----------|
| Nbhd    | BBAY        |  | NOTE   |          |         | LAND    | 241,500  | 213,700 |          |
| Infl1   | AVG         |  |        | BUILDING | 564,000 | 534,300 |          |         |          |
| N_Index | AVG         |  |        | DETACHED | 1,800   | 1,400   |          |         |          |
|         |             |  |        | OTHER    | 0       | 0       |          |         |          |
|         |             |  |        | TOTAL    | 807,300 | 749,400 |          |         |          |

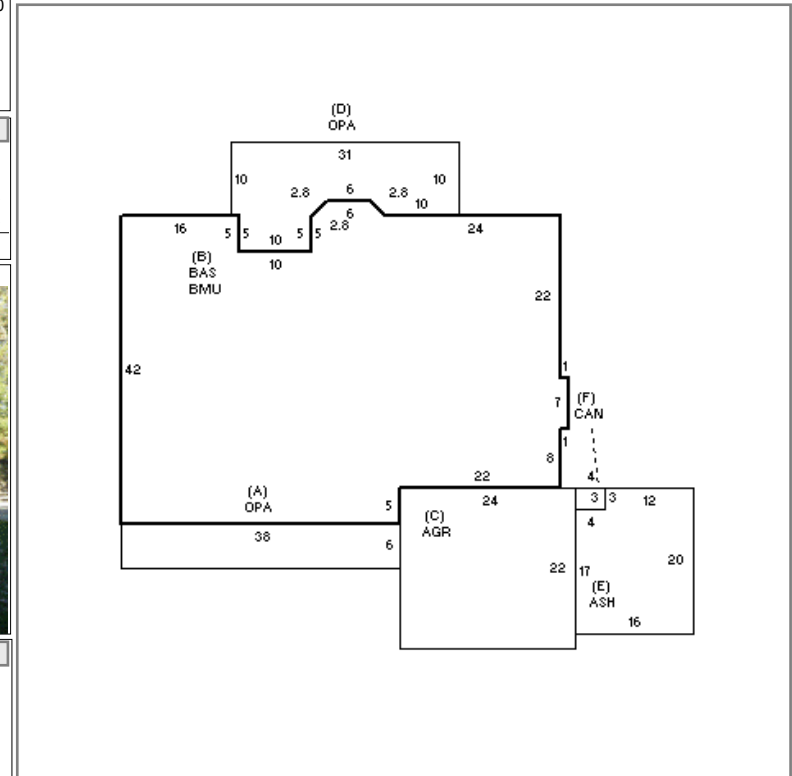

DETACHED

| TY  | QUAL | COND | DIM/NOTE | YB      | UNITS | ADJ PRICE | RCNLD | PHOTO | 10/20/2022 |
|-----|------|------|----------|---------|-------|-----------|-------|-------|------------|
| SHF | A    | 1.00 | 10 0.90  | 10 X 12 |       | 120       | 16.42 | 1,800 |            |

BUILDING

| BUILDING | CD | ADJ  | DESC              | MEASURE | 10/20/2022 | SL  |
|----------|----|------|-------------------|---------|------------|-----|
| MODEL    | 1  |      | RESIDENTIAL       | LIST    | 10/20/2022 | VER |
| STYLE    | 1  | 0.95 | RANCH [100%]      | REVIEW  | 10/20/2022 | SL  |
| QUALITY  | G  | 1.10 | GOOD [100%]       |         |            |     |
| FRAME    | 1  | 1.00 | WOOD FRAME [100%] |         |            |     |

| YEAR BLT   | 2005  | SIZE ADJ   | 1.005 | ELEMENT         | CD | DESCRIPTION    | ADJ  | S | BAT | T | DESCRIPTION     | UNITS | YB   | ADJ PRICE | RCN     | TOTAL RCN | 648,235 |
|------------|-------|------------|-------|-----------------|----|----------------|------|---|-----|---|-----------------|-------|------|-----------|---------|-----------|---------|
| NET AREA   | 2,383 | DETAIL ADJ | 1.000 | FOUNDATION      | 4  | FLR/WALL(FULL) | 1.00 | + | OPA | N | OPEN PORCH      | 572   |      | 65.06     | 37,214  |           |         |
| \$NLA(RCN) | \$272 | OVERALL    | 1.000 | EXT COVER       | 4  | VINYL          | 1.00 | B | BMU | N | BSMT UNFINISHED | 2,383 |      | 31.77     | 75,698  |           |         |
|            |       |            |       | ROOF SHAPE      | 1  | GABLE          | 1.00 | B | BAS | L | BASE AREA       | 2,383 | 2005 | 190.00    | 452,760 |           |         |
|            |       |            |       | ROOF COVER      | 1  | ASPH/COMP SHIN | 1.00 | C | AGR | N | ATT GARAGE      | 528   |      | 68.33     | 36,076  |           |         |
|            |       |            |       | FLOOR COVER     | 1  | HARDWOOD       | 1.02 | E | ASH | N | ATT SHED        | 308   |      | 23.03     | 7,093   |           |         |
|            |       |            |       | INT. FINISH     | 2  | DRYWALL        | 1.00 | F | CAN | N | CANOPY          | 12    |      | 17.13     | 206     |           |         |
|            |       |            |       | HEATING/COOLING | 9  | WARM-COOL AIR  | 1.03 |   | FIX | O | XTRA FIXTURES   | 6     |      | 2,354.35  | 14,126  |           |         |
|            |       |            |       | FUEL SOURCE     | 2  | GAS            | 1.00 |   | GFP | O | GAS FIREPLACE   | 1     |      | 7,075.20  | 7,075   |           |         |
|            |       |            |       | USE             | 0  |                | 1.00 |   | JAC | O | JACUZZI         | 1     |      | 13,575.50 | 13,576  |           |         |
|            |       |            |       |                 |    |                |      |   | MST | O | MAS/METAL STACK | 1     |      | 4,412.10  | 4,412   |           |         |

| CONDITION ELEM | CD |
|----------------|----|
| EXTERIOR       | A  |
| INTERIOR       | A  |
| KITCHEN        | A  |
| BATHS          | A  |
| HEAT           | A  |
| ELECT          | A  |

| EFF.YR/AGE | 2006 / 16 |         |
|------------|-----------|---------|
| COND       | 13        | 13 %    |
| FUNC       | 0         |         |
| ECON       | 0         |         |
| DEPR       | 13        | % GD 87 |
| RCNLD      | \$564,000 |         |