

Key: 3422

### Town of Bourne - Fiscal Year 2024

12/18/2023 6:02 pm SEQ #: 3.462

LEGAL

CURRENT OWNER				PARCEL ID				LOCATION			
MANERO JOSEPH ETUX CATHERINE MANERO 205 STOW RD HARVARD, MA 01451				19.2-112-0				16 QUAMHASSET RD			
TRANSFER HISTORY				DOS	T	SALE PRICE	BK-PG (Cert)				
MANERO JOSEPH ETUX				10/19/2016	QS	400,000	30016-311				
OLSON DIANNE M				07/15/1998	QS	170,000	11571-188				

CLASS	CLASS%	DESCRIPTION			BN ID	BN	CARD	
1010	100	SINGLE FAMILY				1	1 of 1	
PMT NO	PMT DT	TY	DESC	AMOUNT	INSP	BY	1st	%
17542	07/12/2017	9	DECK	5,000	04/24/2018	BC	100	100
09348	07/29/2009	9	DECK	12,600	06/03/2014	JB	100	100

LAND

CD	T	AC/SF/UN	Nbhd	Infl1	N Index	ADJ BASE	SAF	Topo	Lpi	VC	CREDIT AMT	ADJ VALUE
100	S	15,170 4	1.00	100	1.00	100	1.00					
						318,195	2.16	A	1.00	BGD	1.35	239,530

TOTAL	15,159 SF	ZONING	1	FRNT	293	ASSESSED	CURRENT	PREVIOUS
Nbhd	BBAY	NOTE				LAND	239,500	212,000
Infl1	AVG		BUILDING	341,300	302,100			
N_Index	AVG		DETACHED	0	0			
			OTHER	0	0			
						<b>TOTAL</b>	<b>580,800</b>	<b>514,100</b>

DETACHED

TY	QUAL	COND	DIM/NOTE	YB	UNITS	ADJ PRICE	RCNLD	PHOTO	04/24/2018

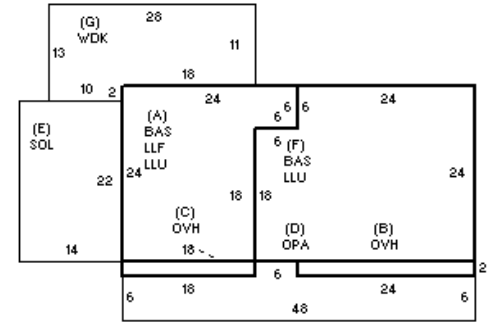

BUILDING

BUILDING	CD	ADJ	DESC	MEASURE	4/24/2018	BC
MODEL	1		RESIDENTIAL	LIST	4/24/2018	BC
STYLE	2	1.00	RAISED RANCH [100%]	REVIEW	7/23/2018	BC
QUALITY	A	1.00	AVERAGE [100%]			
FRAME	1	1.00	WOOD FRAME [100%]			

YEAR BLT	1968	SIZE ADJ	1.005	ELEMENT	CD	DESCRIPTION	ADJ	S	BAT	T	DESCRIPTION	UNITS	YB	ADJ PRICE	RCN	TOTAL RCN	449.061
NET AREA	2,204	DETAIL ADJ	1.000	FOUNDATION	4	FLR/WALL(FULL)	1.00	+	LLU	N	LOWER LEVEL UNF	1,152		34.13	39,319		
\$NLA(RCN)	\$204	OVERALL	1.060	EXT COVER	1	WOOD SHINGLE	1.02	A	LLF	L	LOWER LEVEL FIN	468	1968	65.73	30,764		
				ROOF SHAPE	1	GABLE	1.00	+	BAS	L	BASE AREA	1,152	1968	204.50	235,586		
				ROOF COVER	1	ASPH/COMP SHIN	1.00	+	OVH	L	OVERHANG	84	1968	192.92	18,205		
				FLOOR COVER	1	HARDWOOD	1.02	D	OPA	N	OPEN PORCH	300		62.70	18,809		
				INT. FINISH	2	DRYWALL	1.00	E	SOL	N	SOLARIUM	308		91.87	28,297		
				HEATING/COOLING	2	HOT WATER	1.02	G	WDK	N	WOOD DECK	328		22.75	7,464		
				FUEL SOURCE	2	GAS	1.00		LLF	L	LOWER LEVEL FIN	500	1968	65.73	32,867		
				USE	0		1.00		BMG	O	BSMT GARAGE	2		7,593.45	15,187		
									F12	O	FPL 1S 2OP	1		8,969.80	8,970		
									FIX	O	XTRA FIXTURES	5		2,268.66	11,343		
									MST	O	MAS/METAL STACK	1		4,251.60	4,252		

CONDITION ELEM	CD
EXTERIOR	A
INTERIOR	A
KITCHEN	A
BATHS	A
HEAT	A
ELECT	A

EFF.YR/AGE	1995 / 27
COND	24 24 %
FUNC	0
ECON	0
DEPR	24 % GD 76

RCNLD	\$341,300
-------	-----------