

Key: 3463

Town of Bourne - Fiscal Year 2024

12/18/2023 6:02 pm SEQ #: 3.505

LEGALS

CURRENT OWNER				PARCEL ID				LOCATION			
MURPHY ELLEN MAUREEN 33 STUDIO DRIVE BOURNE, MA 02532				19.3-16-0				33 STUDIO DR			
TRANSFER HISTORY				DOS	T	SALE PRICE	BK-PG (Cert)				
MURPHY ELLEN MAUREEN				02/01/2019	QS	542,500	(218526)				
CHICKOSKY DARLENE M				08/13/2013	F	1	(201149)				
CHICKOSKY RONALD K AND				04/30/1998	QS	253,000	(148326)				

CLASS	CLASS%	DESCRIPTION		BN ID	BN	CARD	
1010	100	SINGLE FAMILY			1	1 of 1	
PMT NO	PMT DT	TY	DESC	AMOUNT	INSP	BY	1st %
18845	10/10/2018	3	ALT/RENO		07/17/2020	TL	100 100
		6	FENCE	1,787			100 100

LAND

CD	T	AC/SF/UN	Nbhd	Infl1	N Index	ADJ BASE	SAF	Topo	Lpi	VC	CREDIT AMT	ADJ VALUE
100	S	22,350 4		1.00	100 1.00	353,550	1.56	A	1.00	BVG	1.50	283,040

TOTAL	22,346 SF	ZONING	1	FRNT	110	ASSESSED	CURRENT	PREVIOUS
Nbhd	BBAY	NOTE				LAND	283,000	250,500
Infl1	AVG		BUILDING	457,200	404,500			
N_Index	AVG		DETACHED	0	0			
			OTHER	0	0			
						<b>TOTAL</b>	<b>740,200</b>	<b>655,000</b>

DETACHED

TY	QUAL	COND	DIM/NOTE	YB	UNITS	ADJ PRICE	RCNLD	PHOTO	08/17/2020
									

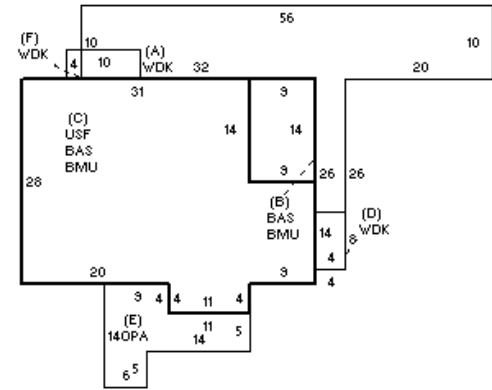

BUILDING

BUILDING	CD	ADJ	DESC	MEASURE	5/3/2018	KT
MODEL	1		RESIDENTIAL	LIST	5/3/2018	EST
STYLE	8	1.10	CONTEMPORARY [100%]	REVIEW	10/20/2020	RP
QUALITY	G	1.10	GOOD [100%]			
FRAME	1	1.00	WOOD FRAME [100%]			

BLDG COMMENTS		

G

YEAR BLT	1986	SIZE ADJ	1.005	ELEMENT	CD	DESCRIPTION	ADJ	S	BAT	T	DESCRIPTION	UNITS	YB	ADJ PRICE	RCN	TOTAL RCN	557,530
NET AREA	2,222	DETAIL ADJ	1.000	FOUNDATION	4	FLR/WALL(FULL)	1.00	+	WDK	N	WOOD DECK	736		26.92	19,813		
\$NLA(RCN)	\$251	OVERALL	1.140	EXT COVER	10	VERT BOARD	1.00	+	BMU	N	BSMT UNFINISHED	1,164		45.96	53,492		
				ROOF SHAPE	1	GABLE	1.00	+	BAS	L	BASE AREA	1,164	1986	241.93	281,605		
				ROOF COVER	1	ASPH/COMP SHIN	1.00	C	USF	L	UPPER STORY FIN	1,038	1986	131.03	136,007		
				FLOOR COVER	2	SOFTWOOD	1.02	E	OPA	N	OPEN PORCH	166		82.37	13,674		
				INT. FINISH	2	DRYWALL	1.00		OVH	L	OVERHANG	20	1986	228.24	4,565		
				HEATING/COOLING	2	HOT WATER	1.02		BMG	O	BSMT GARAGE	2		8,983.20	17,966		
				FUEL SOURCE	1	OIL	1.00		F22	O	FPL 2S 2OP	1		11,620.90	11,621		
				USE	0		1.00		FIX	O	XTRA FIXTURES	7		2,683.83	18,787		

CONDITION ELEM	CD
EXTERIOR	A
INTERIOR	A
KITCHEN	G
BATHS	G
HEAT	A
ELECT	A

EFF.YR/AGE	2001 / 21	
COND	18	18 %
FUNC	0	
ECON	0	
DEPR	18	% GD 82

RCNLD	\$457,200
-------	-----------