

Key: 3567

Town of Bourne - Fiscal Year 2024

12/18/2023 6:02 pm SEQ #: 3.618

LEGAL

LAND

DETACHED

BUILDING

CURRENT OWNER				PARCEL ID				LOCATION			
WILLIAMSON DEVELOPMENT LLC 45 MOVILLE ST WEST ROXBURY, MA 02132				19.3-133-0				10 STUDIO DR			
TRANSFER HISTORY				DOS	T	SALE PRICE		BK-PG (Cert)			
WILLIAMSON DEVELOPMENT LL				10/07/2014	B	80,000		(204634)			
SALVUCCI ANTHONY J & LORR				04/23/2002	F	1		(164973)			
SALVUCCI ANTHONY J &					XX	00812-00024					

CLASS	CLASS%	DESCRIPTION			BN ID	BN	CARD	
1010	100	SINGLE FAMILY				1	1 of 1	
PMT NO	PMT DT	TY	DESC	AMOUNT	INSP	BY	1st	%
14824	09/29/2014	1	NEW CONSTRUC	141,000	08/09/2016	TL	100	100

CD	T	AC/SF/UN	Nbhd	Infl1	N Index	ADJ BASE	SAF	Topo	Lpi	VC	CREDIT AMT	ADJ VALUE										
100	S	14,400 4	1.00	100	1.00	100	1.00	235,700	2.26	A	1.00	R03	1.00									176,220

TOTAL	14,418 SF	ZONING	1	FRNT	80	ASSESSED	CURRENT	PREVIOUS
Nbhd	BBAY	NOTE	LAND	176,200	156,000			
Infl1	AVG		BUILDING	389,600	348,400			
N_Index	AVG		DETACHED	0	0			
			OTHER	0	0			
			TOTAL	565,800	504,400			

TY	QUAL	COND	DIM/NOTE	YB	UNITS	ADJ PRICE	RCNLD



BLDG COMMENTS

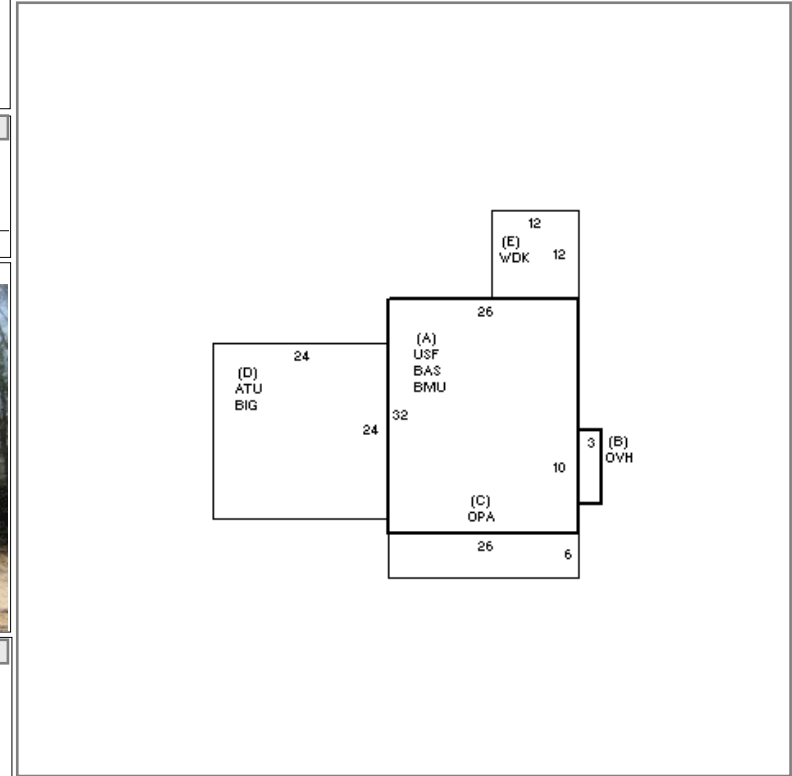

BUILDING	CD	ADJ	DESC	MEASURE	5/24/2022	RP
MODEL	1		RESIDENTIAL	LIST	5/24/2022	EST
STYLE	5	1.00	COLONIAL [100%]	REVIEW	5/24/2022	RP
QUALITY	A	1.00	AVERAGE [100%]			
FRAME	1	1.00	WOOD FRAME [100%]			

YEAR BLT	2015	SIZE ADJ	1.010	ELEMENT	CD	DESCRIPTION	ADJ	S	BAT	T	DESCRIPTION	UNITS	YB	ADJ PRICE	RCN	
NET AREA	1,694	DETAIL ADJ	1.000	FOUNDATION	4	FLR/WALL(FULL)	1.00	A	BMU	N	BSMT UNFINISHED	832		38.30	31,868	
\$NLA(RCN)	\$240	OVERALL	1.040	EXT COVER	15	VINYL SHINGLE	1.02	A	BAS	L	BASE AREA	832	2015	208.30	173,304	
CAPACITY			UNITS	ADJ	ROOF SHAPE	1	GABLE	1.00	A	USF	L	UPPER STORY FIN	832	2015	113.08	94,079
STORIES	2	1.00	ROOF COVER	1	ASPH/COMP SHIN	1.00	B	OVH	L	OVERHANG	30	2015	190.23	5,707		
ROOMS	7	1.00	FLOOR COVER	1	HARDWOOD	1.02	C	OPA	N	OPEN PORCH	156		68.65	10,710		
BEDROOMS	3	1.00	INT. FINISH	1	PLASTER	1.00	D	BIG	N	BUILT-IN GARAGE	576		82.36	47,437		
BATHROOMS	2	1.00	HEATING/COOLING	1	FORCED AIR	1.00	D	ATU	N	ATTIC UNF	576		44.40	25,572		
FIXTURES	10	1.00	FUEL SOURCE	2	GAS	1.00	E	WDK	N	WOOD DECK	144		41.51	5,977		
GARAGE CAPACITY	2	1.00	USE	0		1.00		FIX	O	XTRA FIXTURES	5		2,236.94	11,185		
% BSMT FINISH	0	1.00														
# OF HALF BATHS	1	1.00														
# OF UNITS	1	1.00														

TOTAL RCN	405,839
CONDITION ELEM	CD
EXTERIOR	A
INTERIOR	A
KITCHEN	A
BATHS	A
HEAT	A
ELECT	A
EFF.YR/AGE	2015 / 7
COND	4 4 %
FUNC	0
ECON	0
DEPR	4 % GD 96
RCNLD	\$389,600