

Key: 3710

Town of Bourne - Fiscal Year 2024

12/18/2023 6:02 pm SEQ #: 3.762

LEGAL

LAND

DETACHED

BUILDING

CURRENT OWNER				PARCEL ID				LOCATION			
SMITH HELEN 22 QUEENS BAY LN BUZZARDS BAY, MA 02532				19.4-96-0				22 QUEENS BAY LN			
TRANSFER HISTORY				DOS	T	SALE PRICE	BK-PG (Cert)				
SMITH HELEN SMITH ROBERT T &				03/29/2022	F XX		1 35006-329 01123-0315				

CLASS	CLASS%	DESCRIPTION			BN ID	BN	CARD	
1010	100	SINGLE FAMILY				1	1 of 1	
PMT NO	PMT DT	TY	DESC	AMOUNT	INSP	BY	1st	%
05530	08/10/2005	3	ALT/RENO	3,000	04/05/2006	TL	100	100
01231	05/04/2001	3	ALT/RENO	5,647	06/27/2002	TL	100	100

CD	T	AC/SF/UN	Nbhd	Infl1	N Index	ADJ BASE	SAF	Topo	Lpi	VC	CREDIT AMT	ADJ VALUE
100	S	14,720 4		1.00 100	1.00 100	235,700	2.22	A	1.00 R03	1.00		176,720

TOTAL	14,723 SF	ZONING	1	FRNT	119	ASSESSED	CURRENT	PREVIOUS
Nbhd	BBAY	NOTE	LAND	176,700	156,400			
Infl1	AVG		BUILDING	246,900	218,000			
N_Index	AVG		DETACHED	0	0			
			OTHER	0	0			
			TOTAL	423,600	374,400			

TY	QUAL	COND	DIM/NOTE	YB	UNITS	ADJ PRICE	RCNLD
SHF	A	1.00 50 0.50	8 X 12			0.00	

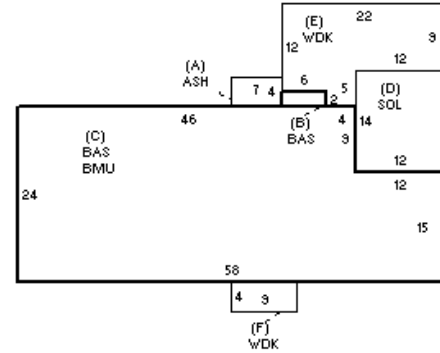

BUILDING	CD	ADJ	DESC	MEASURE	10/5/2022	SL
MODEL	1		RESIDENTIAL	LIST	11/4/2022	SL
STYLE	1	0.95	RANCH [100%]	REVIEW	11/4/2022	SL
QUALITY	A	1.00	AVERAGE [100%]			
FRAME	1	1.00	WOOD FRAME [100%]			

BLDG COMMENTS

YEAR BLT	1950	SIZE ADJ	1.015	ELEMENT	CD	DESCRIPTION	ADJ	S	BAT	T	DESCRIPTION	UNITS	YB	ADJ PRICE	RCN	TOTAL RCN	324,914
NET AREA	1,296	DETAIL ADJ	1.000	FOUNDATION	4	FLR/WALL(FULL)	1.00	A	ASH	N	ATT SHED	28		23.97	671		
\$NLA(RCN)	\$251	OVERALL	0.950	EXT COVER	4	VINYL	1.00	+	BAS	L	BASE AREA	1,296	1950	181.26	234,914		
				ROOF SHAPE	1	GABLE	1.00	C	BMU	N	BSMT UNFINISHED	1,284		30.80	39,553		
				ROOF COVER	1	ASPH/COMP SHIN	1.00	D	SOL	N	SOLARIUM	168		92.42	15,526		
				FLOOR COVER	35	WW-VINYL	1.00	+	WDK	N	WOOD DECK	272		24.97	6,793		
				INT. FINISH	2	DRYWALL	1.00		BSF	N	BSMT SEMI-FIN	400		23.64	9,457		
				HEATING/COOLING	1	FORCED AIR	1.00		F11	O	FPL 1S 1OP	1		7,731.40	7,731		
				FUEL SOURCE	2	GAS	1.00		FIX	O	XTRA FIXTURES	5		2,053.46	10,267		
				USE	0		1.00										
																CONDITION ELEM	CD
																EXTERIOR	A
																INTERIOR	A
																KITCHEN	A
																BATHS	A
																HEAT	A
																ELECT	A
																EFF.YR/AGE	1995 / 27
																COND	24 24 %
																FUNC	0
																ECON	0
																DEPR	24 % GD 76
																RCNLD	\$246,900