

Key: 3852

Town of Bourne - Fiscal Year 2024

12/18/2023 6:02 pm SEQ #: 3.902

LEGALS

CURRENT OWNER				PARCEL ID				LOCATION			
ORTH CHRISTINE N 12 BLUEBERRY RD BUZZARDS BAY, MA 02532				19.4-234-0				12 BLUEBERRY RD			
TRANSFER HISTORY				DOS	T	SALE PRICE	BK-PG (Cert)				
ORTH CHRISTINE N				03/30/2009	QS	263,000	(188216)				
FERREIRA DEBORAH L				08/25/2003	QS	270,000	(170306)				
LEVECQUE JOHN S ETUX				04/19/2002	F	1	(160521)				

CLASS	CLASS%	DESCRIPTION		BN ID	BN	CARD	
1010	100	SINGLE FAMILY			1	1 of 1	
PMT NO	PMT DT	TY	DESC	AMOUNT	INSP	BY	1st %
18504		3	ALT/RENO		08/25/2022	SL	100 100
03713	06/14/2018	3	ALT/RENO			TL	100 100
960247	10/02/2003	4	DETACH.STRUC	1,145	11/05/2003	TL	100 100
950178	06/07/1996	2	ADDITIONS	5,000	04/16/1997	JS	100 100
	04/14/1995	9	DECK	2,000	07/23/1996	JS	100 100

LAND

CD	T	AC/SF/UN	Nbhd	Infl1	N Index	ADJ BASE	SAF	Topo	Lpi	VC	CREDIT AMT	ADJ VALUE
100	S	8,630 4		1.00	1.00	235,700	3.58	A	1.00	R03	1.00	167,170

DETACHED

TOTAL	8,625 SF	ZONING	1	FRNT	140	ASSESSED	CURRENT	PREVIOUS
Nbhd	BBAY	NOTE				LAND	167,200	148,000
Infl1	AVG		BUILDING	308,400	272,900			
N_Index	AVG		DETACHED	0	0			
			OTHER	0	0			
						TOTAL	475,600	420,900

BUILDING

TY	QUAL	COND	DIM/NOTE	YB	UNITS	ADJ PRICE	RCNLD	PHOTO	08/25/2022
SHF	A	1.00	A 0.75 6 X 8			0.00			
SHF	A	1.00	A 0.75 8X12			0.00			

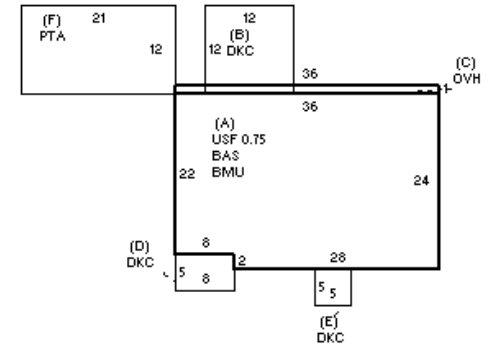

BUILDING	CD	ADJ	DESC	MEASURE	8/25/2022	SL
MODEL	1		RESIDENTIAL	LIST	8/25/2022	EST
STYLE	4	1.05	CAPE [100%]	REVIEW	9/6/2022	TL
QUALITY	+	1.05	AVERAGE + [100%]			
FRAME	1	1.00	WOOD FRAME [100%]			

BLDG COMMENTS

G

YEAR BLT	1947	SIZE ADJ	1.010	ELEMENT	CD	DESCRIPTION	ADJ	S	BAT	T	DESCRIPTION	UNITS	YB	ADJ PRICE	RCN	TOTAL RCN	350,436
NET AREA	1,520	DETAIL ADJ	1.000	FOUNDATION	3	FOUN. WALL	1.00	A	BMU	N	BSMT UNFINISHED	848		42.92	36,400		
\$NLA(RCN)	\$231	OVERALL	1.110	EXT COVER	1	WOOD SHINGLE	1.02	A	BAS	L	BASE AREA	848	1947	233.43	197,953		
				ROOF SHAPE	1	GABLE	1.00	A	USF	L	UPPER STORY FIN	636	1947	128.00	81,405		
				ROOF COVER	1	ASPH/COMP SHIN	1.00	+	DKC	N	DECK-COMPOSITE	209		73.91	15,448		
				FLOOR COVER	1	HARDWOOD	1.02	C	OVH	L	OVERHANG	36	1947	213.20	7,675		
				INT. FINISH	1	PLASTER	1.00	F	PTA	N	PATIO	252		16.01	4,034		
				HEATING/COOLING	2	HOT WATER	1.02		FIX	O	XTRA FIXTURES	3		2,506.93	7,521		
				FUEL SOURCE	2	GAS	1.00										
				USE	0		1.00										

CONDITION ELEM	CD
EXTERIOR	A
INTERIOR	A
KITCHEN	G
BATHS	G
HEAT	U
ELECT	U

EFF.YR/AGE	2007 / 15
COND	12 12 %
FUNC	0
ECON	0
DEPR	12 % GD 88
RCNLD	\$308,400