

Key: 4500

Town of Bourne - Fiscal Year 2024

12/18/2023 6:02 pm SEQ #: 4.585

LEGALS

CURRENT OWNER				PARCEL ID				LOCATION			
GRASSO PETER A ETUX ALLISON J GRASSO 37 BUTTERMILK WAY BUZZARDS BAY, MA 02532				23.1-128-0				37 BUTTERMILK WAY			
TRANSFER HISTORY				DOS	T	SALE PRICE		BK-PG (Cert)			
GRASSO PETER A ETUX				11/13/2014	T	280,000		28504-106			
WHIPPLE DAVID L				11/13/2014	F	28504-103+4					
WHIPPLE PAULINE A &				05/23/1988	F	1 6269-276					

CLASS	CLASS%	DESCRIPTION		BN ID	BN	CARD	
1010	100	SINGLE FAMILY			1	1 of 1	
PMT NO	PMT DT	TY	DESC	AMOUNT	INSP	BY	1st %
17106	02/10/2017	3	ALT/RENO	9,900	03/19/2018	TL	100 100
16370	05/10/2016	6	FENCE	4,496	09/08/2016	TL	100 100
15728	08/20/2015	1	NEW CONSTRU	248,600	09/08/2016	TL	100 100

LAND

CD	T	AC/SF/UN	Nbhd	Infl1	N Index	ADJ BASE	SAF	Topo	Lpi	VC	CREDIT AMT	ADJ VALUE					
100	S	8,580	5	1.00	100	1.00	100	1.00	707,100	3.60	A	1.00	BSP	3.00			501,260

TOTAL	8,581 SF	ZONING	1	FRNT	70	ASSESSED	CURRENT	PREVIOUS
Nbhd	TAY PT	N O T E	2nd flr bdrms & open media rm have min.ceiling height, duct work in eves = usf.50; ea has sliders out to own deck			LAND	501,300	443,600
Infl1	AVG		BUILDING	695,100	621,700			
N_Index	AVG		DETACHED	0	0			
						OTHER	0	0
						TOTAL	1,196,400	1,065,300

DETACHED

TY	QUAL	COND	DIM/NOTE	YB	UNITS	ADJ PRICE	RCNLD	PHOTO	09/20/2016

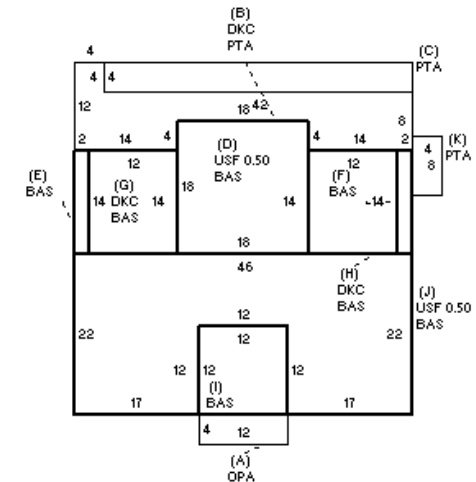

BUILDING

BUILDING	CD	ADJ	DESC	MEASURE	3/19/2018	TL
MODEL	1		RESIDENTIAL	LIST	3/19/2018	TL
STYLE	8	1.10	CONTEMPORARY [100%]	REVIEW	3/19/2018	TL
QUALITY	G	1.10	GOOD [100%]			
FRAME	1	1.00	WOOD FRAME [100%]			

BLDG COMMENTS		

G

YEAR BLT	2015	SIZE ADJ	1.005	ELEMENT	CD	DESCRIPTION	ADJ	S	BAT	T	DESCRIPTION	UNITS	YB	ADJ PRICE	RCN	TOTAL RCN	724.067
NET AREA	2,324	DETAIL ADJ	1.000	FOUNDATION	3	FOUN. WALL	1.00	A	OPA	N	OPEN PORCH	48		105.39	5,059	CONDITION ELEM	CD
\$NLA(RCN)	\$312	OVERALL	1.170	EXT COVER	15	VINYL SHINGLE	1.02	+	PTA	N	PATIO	512		17.59	9,005	EXTERIOR	A
				ROOF SHAPE	1	GABLE	1.00	+	DKC	N	DECK-COMPOSITE	648		80.25	52,005	INTERIOR	A
				ROOF COVER	1	ASPH/COMP SHIN	1.00	+	BAS	L	BASE AREA	1,728	2015	229.09	395,864	KITCHEN	A
				FLOOR COVER	1	HARDWOOD	1.02	+	USF	L	UPPER STORY FIN	596	2015	142.32	84,824	BATHS	A
				INT. FINISH	1	PLASTER	1.00		BIG	N	BUILT-IN GARAGE	1,776		90.53	160,784	HEAT	A
				HEATING/COOLING	9	WARM-COOL AIR	1.03		FIX	O	XTRA FIXTURES	6		2,754.58	16,528	ELECT	A
				FUEL SOURCE	2	GAS	1.00										
				USE	0		1.00										

EFF.YR/AGE	2015 / 7
COND	4 4 %
FUNC	0
ECON	0
DEPR	4 % GD 96
RCNLD	\$695,100